



US008743076B1

(12) **United States Patent**  
**Ludwig**

(10) **Patent No.:** **US 8,743,076 B1**  
(45) **Date of Patent:** **\*Jun. 3, 2014**

(54) **SENSOR ARRAY TOUCHSCREEN  
RECOGNIZING FINGER FLICK GESTURE  
FROM SPATIAL PRESSURE DISTRIBUTION  
PROFILES**

(71) Applicant: **Lester F. Ludwig**, San Antonio, TX  
(US)

(72) Inventor: **Lester F. Ludwig**, San Antonio, TX  
(US)

(73) Assignee: **Lester F. Ludwig**, San Antonio, TX  
(US)

(\*) Notice: Subject to any disclaimer, the term of this  
patent is extended or adjusted under 35  
U.S.C. 154(b) by 0 days.

This patent is subject to a terminal dis-  
claimer.

(21) Appl. No.: **14/160,511**

(22) Filed: **Jan. 21, 2014**

**Related U.S. Application Data**

(60) Continuation of application No. 11/761,978, filed on  
Jun. 12, 2007, which is a continuation of application  
No. 09/812,400, filed on Mar. 19, 2001, now Pat. No.  
7,786,370, which is a division of application No.  
09/313,533, filed on May 15, 1999, now Pat. No.  
6,610,917.

(60) Provisional application No. 60/085,713, filed on May  
15, 1998.

(51) **Int. Cl.**  
**G06F 3/041** (2006.01)

(52) **U.S. Cl.**  
USPC ..... **345/173**; 178/18.01

(58) **Field of Classification Search**  
USPC ..... 345/173-179; 178/18.01-18.09  
See application file for complete search history.

(56) **References Cited**

U.S. PATENT DOCUMENTS

4,748,676 A 5/1988 Miyagawa  
4,899,137 A 2/1990 Behrens et al.  
4,988,981 A 1/1991 Zimmerman

(Continued)

FOREIGN PATENT DOCUMENTS

EP 0 574 213 A1 12/1993

OTHER PUBLICATIONS

Dulberg, M. S., et al. An Imprecise Mouse Gesture for the Fast  
Activation of Controls, IOS Press, Aug. 1999, [online] [retrieved on  
Jul. 9, 2013] URL: [http://www.csc.ncsu.edu/faculty/stamant/papers/  
interact.pdf.gz](http://www.csc.ncsu.edu/faculty/stamant/papers/interact.pdf.gz), 10 pgs.

(Continued)

*Primary Examiner* — Premal Patel

(74) *Attorney, Agent, or Firm* — Procopio, Cory,  
Hargreaves & Savitch, LLP

(57) **ABSTRACT**

Touch screen user interfaces configured to detect a touch  
gesture for controlling software applications, computers,  
devices, machinery, and process environments. Such user  
interfaces can be manipulated by users and provide a wide  
range of uses with computer applications, assistance to the  
disabled, and control of electronic devices, machines, and  
processes. Enhancements can include velocity and pressure  
sensing capabilities. The touch screen can be realized with a  
transparent touch sensor array positioned over a visual dis-  
play. The touch screen can be configured to measure a spatial  
pressure distribution profile from a touch on the touch screen  
and recognize gestures based on dynamics among spatial  
pressure distribution profiles. In an example implementation,  
the gesture recognition may rely solely on dynamics of shape  
differences between hand contact patterns and omit the use of  
pressure, as the shape of the spatial pressure distribution  
profile does not vary much by pressure.

**18 Claims, 7 Drawing Sheets**

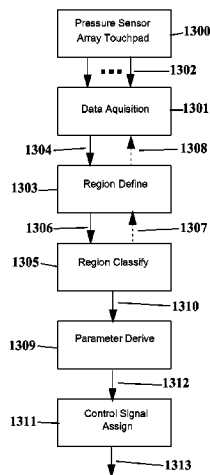

(56)

References Cited

U.S. PATENT DOCUMENTS

5,168,531	A	12/1992	Sigel	6,310,279	B1	10/2001	Suzuki et al.
5,203,704	A	4/1993	McCloud	6,310,610	B1	10/2001	Beaton et al.
5,214,615	A	5/1993	Bauer	6,320,112	B1	11/2001	Lotze
5,237,647	A	8/1993	Roberts et al.	6,323,846	B1	11/2001	Westerman et al.
5,270,711	A	12/1993	Knapp	6,360,019	B1	3/2002	Chaddha
5,292,999	A	3/1994	Tumura	6,363,159	B1	3/2002	Rhoads
5,341,133	A	8/1994	Savoy	6,373,475	B1	4/2002	Challis
5,342,054	A	8/1994	Chang	6,392,636	B1	5/2002	Ferrari
5,347,295	A	9/1994	Agulnick et al.	6,392,705	B1	5/2002	Chaddha
5,357,048	A	10/1994	Sgroi	6,400,836	B2*	6/2002	Senior ..... 382/124
5,378,850	A	1/1995	Tumura	6,404,898	B1	6/2002	Rhoads
5,386,219	A*	1/1995	Greanias et al. .... 345/174	6,408,087	B1	6/2002	Kramer
5,420,936	A*	5/1995	Fitzpatrick et al. .... 382/124	6,433,801	B1	8/2002	Moon
5,440,072	A	8/1995	Willis	6,509,847	B1	1/2003	Anderson
5,442,168	A	8/1995	Gurner et al.	6,570,078	B2	5/2003	Ludwig
5,454,043	A	9/1995	Freeman	6,610,917	B2	8/2003	Ludwig
5,459,282	A	10/1995	Willis	6,703,552	B2	3/2004	Haken
5,471,008	A	11/1995	Fujita et al.	6,793,619	B1	9/2004	Blumental
5,475,214	A	12/1995	DeFranco et al.	7,030,860	B1	4/2006	Hsu et al.
5,483,261	A	1/1996	Yasutake	7,408,108	B2	8/2008	Ludwig
5,531,227	A	7/1996	Schneider	7,557,797	B2	7/2009	Ludwig
5,565,641	A	10/1996	Gruenbaum	7,598,949	B2	10/2009	Han
5,585,588	A	12/1996	Tumura	7,611,409	B2	11/2009	Muir et al.
5,592,572	A	1/1997	Le	7,936,341	B2	5/2011	Weiss
5,592,752	A	1/1997	Fu	8,049,730	B2	11/2011	Joguet
5,594,469	A	1/1997	Freeman	8,154,529	B2	4/2012	Sleeman
5,598,208	A	1/1997	McClintock	8,169,414	B2	5/2012	Lim
5,617,855	A	4/1997	Waletzky	8,170,346	B2	5/2012	Ludwig
5,625,704	A	4/1997	Prasad	8,179,376	B2	5/2012	Griffin
5,659,145	A	8/1997	Weil	8,345,014	B2	1/2013	Lim
5,659,466	A	8/1997	Norris et al.	2001/0012000	A1	8/2001	Eberhard
5,659,625	A	8/1997	Marquardt	2001/0036299	A1	11/2001	Senior
5,662,111	A	9/1997	Cosman	2002/0005108	A1	1/2002	Ludwig
5,665,927	A	9/1997	Taki et al.	2002/0093491	A1	7/2002	Gillespie et al.
5,668,338	A	9/1997	Hewitt et al.	2003/0003976	A1	1/2003	Mura
5,675,100	A	10/1997	Hewlett	2003/0151592	A1	8/2003	Ritter
5,703,303	A	12/1997	Stewart	2004/0074379	A1	4/2004	Ludwig
5,717,939	A	2/1998	Bricklin et al.	2004/0118268	A1	6/2004	Ludwig
5,719,347	A	2/1998	Masubachi et al.	2004/0245438	A1	12/2004	Payne
5,719,561	A	2/1998	Gonzales	2004/0251402	A1	12/2004	Reime
5,724,985	A	3/1998	Snell	2005/0078085	A1	4/2005	Casebolt
5,741,993	A	4/1998	Kushimiya	2005/0179651	A1	8/2005	Ludwig
5,748,184	A	5/1998	Shieh	2006/0086896	A1	4/2006	Han
5,763,806	A	6/1998	Willis	2006/0250353	A1	11/2006	Yasutake
5,786,540	A	7/1998	Westlund	2006/0252530	A1	11/2006	Oberberger et al.
5,801,340	A	9/1998	Peter	2006/0267957	A1	11/2006	Kolmykov-Zotov
5,805,137	A	9/1998	Yasutake	2007/0044019	A1	2/2007	Moon
5,808,605	A*	9/1998	Shieh ..... 345/173	2007/0063990	A1	3/2007	Park
5,824,930	A	10/1998	Ura et al.	2007/0216641	A1	9/2007	Young
5,827,989	A	10/1998	Fay et al.	2007/0229477	A1	10/2007	Ludwig
5,841,428	A	11/1998	Jaeger et al.	2007/0236477	A1	10/2007	Ryu
5,850,051	A	12/1998	Machover et al.	2007/0291009	A1	12/2007	Wright
5,852,251	A	12/1998	Su et al.	2008/0001925	A1	1/2008	XiaoPing
5,870,083	A	2/1999	Shieh	2008/0010616	A1	1/2008	Algreatly
5,889,236	A	3/1999	Gillespie et al.	2008/0012832	A1	1/2008	GuangHai
5,932,827	A	8/1999	Osborne et al.	2008/0034286	A1	2/2008	Selby
5,969,283	A	10/1999	Looney et al.	2008/0055263	A1	3/2008	Lemay
5,977,466	A	11/1999	Muramatsu	2008/0091453	A1	4/2008	Meehan
5,986,224	A	11/1999	Kent	2008/0122796	A1	5/2008	Jobs et al.
6,002,808	A	12/1999	Freeman	2008/0143690	A1	6/2008	Jang
6,005,545	A	12/1999	Nishida et al.	2008/0158172	A1	7/2008	Hotelling et al.
6,037,937	A*	3/2000	Beaton et al. .... 715/764	2008/0164076	A1	7/2008	Orsley
6,047,073	A	4/2000	Norris et al.	2008/0168403	A1	7/2008	Westerman et al.
6,051,769	A	4/2000	Brown, Jr.	2008/0259053	A1	10/2008	Newton
6,069,326	A	5/2000	Henson	2008/0297482	A1	12/2008	Weiss
6,071,193	A	6/2000	Suzuoki	2008/0300055	A1	12/2008	Lutnick
6,100,461	A	8/2000	Hewitt	2008/0309634	A1	12/2008	Hotelling et al.
6,107,997	A	8/2000	Ure	2009/0002333	A1	1/2009	Maxwell
6,140,565	A	10/2000	Yamauchi et al.	2009/0006292	A1	1/2009	Block
6,204,441	B1	3/2001	Asahi et al.	2009/0027351	A1	1/2009	Zhang et al.
6,225,975	B1	5/2001	Furuki et al.	2009/0051659	A1	2/2009	Mickelborough
6,256,046	B1	7/2001	Waters	2009/0124348	A1	5/2009	Yoseloff et al.
6,278,443	B1	8/2001	Amro	2009/0146968	A1	6/2009	Narita et al.
6,285,358	B1	9/2001	Roberts	2009/0167701	A1	7/2009	Ronkainen
6,288,317	B1	9/2001	Willis	2009/0254869	A1	10/2009	Ludwig
				2010/0013860	A1	1/2010	Mandella
				2010/0044121	A1	2/2010	Simon
				2010/0060607	A1	3/2010	Ludwig
				2010/0073318	A1	3/2010	Hu

(56)

## References Cited

## U.S. PATENT DOCUMENTS

2010/0079385	A1	4/2010	Holmgren
2010/0079405	A1	4/2010	Bernstein
2010/0087241	A1	4/2010	Nguyen et al.
2010/0090963	A1	4/2010	Dubs
2010/0110025	A1	5/2010	Lim
2010/0117978	A1	5/2010	Shirado
2010/0177118	A1	7/2010	Sytnikov
2010/0231612	A1	9/2010	Chaudhri et al.
2010/0232710	A1	9/2010	Ludwig
2010/0289754	A1	11/2010	Sleeman et al.
2010/0302172	A1	12/2010	Wilairat
2010/0315337	A1	12/2010	Ferren
2010/0328032	A1	12/2010	Rofougaran
2011/0007000	A1	1/2011	Lim
2011/0037735	A1	2/2011	Land
2011/0057953	A1	3/2011	Horodezky
2011/0063251	A1	3/2011	Geaghan
2011/0066984	A1	3/2011	Li
2011/0084928	A1	4/2011	Chang et al.
2011/0086706	A1	4/2011	Zalewski
2011/0170745	A1	7/2011	Chen
2011/0202889	A1	8/2011	Ludwig
2011/0202934	A1	8/2011	Ludwig
2011/0260998	A1	10/2011	Ludwig
2011/0261049	A1	10/2011	Cardno et al.
2011/0285648	A1	11/2011	Simon et al.
2012/0007821	A1	1/2012	Zaliva
2012/0034978	A1	2/2012	Lim
2012/0050185	A1	3/2012	Davydov et al.
2012/0056846	A1	3/2012	Zaliva
2012/0106782	A1	5/2012	Nathan
2012/0108323	A1	5/2012	Kelly et al.
2012/0133484	A1	5/2012	Griffin
2012/0192119	A1	7/2012	Zaliva
2012/0194461	A1	8/2012	Lim
2012/0194462	A1	8/2012	Lim
2012/0195522	A1	8/2012	Ludwig
2012/0223903	A1	9/2012	Ludwig
2012/0235940	A1	9/2012	Ludwig
2012/0262401	A1	10/2012	Rofougaran
2012/0280927	A1	11/2012	Ludwig
2012/0317521	A1	12/2012	Ludwig
2013/0004016	A1	1/2013	Karakotsios
2013/0009896	A1	1/2013	Zaliva
2013/0038554	A1	2/2013	West

## OTHER PUBLICATIONS

Moyle, M., et al. A Flick in the Right Direction: A Case Study of Gestural Input, *Conferences in Research and Practice in Information Technology*, vol. 18, Jan. 2005; New Zealand, [online] [retrieved on Jul. 9, 2013] URL: <http://www.cosc.canterbury.ac.nz/andrew.cockburn/papers/moyle-cockburn.pdf>, 27 pgs.

Maltoni, D., et al., "Handbook of Fingerprint Recognition," Springer Professional Computing, 2nd ed. 2009, XVI, p. 74, p. 361, [online] [retrieved on Jul. 9, 2013] URL: <http://books.google.com/books?id=1Wpx25D8qOwC&pg=PA361&lpg=PA361&dq=fingerprint+minutiae>, 2 pgs.

VeriFinger Information, [online] [retrieved on Jun. 11, 2013] URL: [http://www.fingerprint-it.com/\\_sol\\_verifinger.html](http://www.fingerprint-it.com/_sol_verifinger.html), 2 pgs.

Prabhakar S., et al., Learning fingerprint minutiae location and type, *Pattern Recognition* 2003, 36, [online] URL: [http://www.cse.msu.edu/biometrics/Publications/Fingerprint/PrabhakarJainPankanti\\_MinaLocType\\_PR03.pdf](http://www.cse.msu.edu/biometrics/Publications/Fingerprint/PrabhakarJainPankanti_MinaLocType_PR03.pdf), pp. 1847-1857.

Garcia Reyes, E., An Automatic Goodness Index to Measure Fingerprint Minutiae Quality, *Progress in Pattern Recognition, Image Analysis and Applications, Lecture Notes in Computer Science* vol. 3773, 2005, pp. 578-585, [online] [retrieved on Jun. 2, 2013] URL: [http://www.researchgate.net/publication/226946511\\_An\\_Auto-matic\\_Goodness\\_Index\\_to\\_Measure\\_Fingerprint\\_Minutiae\\_Quality/file/d912f50ba5e96320d5.pdf](http://www.researchgate.net/publication/226946511_An_Auto-matic_Goodness_Index_to_Measure_Fingerprint_Minutiae_Quality/file/d912f50ba5e96320d5.pdf).

Kayaoglu, M., et al., Standard Fingerprint Databases: Manual Minutiae Labeling and Matcher Performance Analyses, arXiv preprint

arXiv:1305.1443, 2013, 14 pgs, [online] [retrieved on Jun. 2, 2013] URL: <http://arxiv.org/ftp/arxiv/papers/1305/1305.1443.pdf>.

Alonso-Fernandez, F., et al., *Fingerprint Recognition, Chapter 4, Guide to Biometric Reference Systems and Performance Evaluation*, (Springer, London, 2009, pp. 51-90, [online] [retrieved on Jun. 2, 2013] URL: <http://www2.hh.se/staff/josef/public/publications/alonso-fernandez09chapter.pdf>.

Image moment, Jul. 12, 2010, 3 pgs, [online] [retrieved on Jun. 13, 2013] URL: [http://en.wikipedia.org/wiki/Image\\_moment](http://en.wikipedia.org/wiki/Image_moment).

Nguyen, N., et al., Comparisons of sequence labeling algorithms and extensions, *Proceedings of the 24th International Conference on Machine Learning*, 2007, [online] [retrieved on Jun. 2, 2013] URL: <http://www.cs.cornell.edu/~nhnguyen/icml07structured.pdf>, pp. 681-688.

Nissen, S., Implementation of a Fast Artificial Neural Network Library (FANN), Department of Computer Science University of Copenhagen (DIKU)}, Oct. 31, 2003, [online] [retrieved on Jun. 21, 2013] URL: [http://mirror.transact.net.au/sourceforge/f/project/fann/fann\\_doc/1.0/fann\\_doc\\_complete\\_1.0.pdf](http://mirror.transact.net.au/sourceforge/f/project/fann/fann_doc/1.0/fann_doc_complete_1.0.pdf), 92 pgs.

Igel, C., et al., Improving the Rprop Learning Algorithm, *Proceedings of the Second International ICSC Symposium on Neural Computation (NC 2000)*, 2000, 2000, [online] [retrieved on Jun. 2, 2013] URL: <http://citeseerx.ist.psu.edu/viewdoc/download?doi=10.1.1.17.3899&rep=rep1&type=pdf>, pp. 115-121.

Bishop, C.M., *Pattern Recognition and Machine Learning*, Springer New York, 2006, pp. 561-593.

Euler Angles, 2011, [online] [retrieved on Jun. 30, 2011] URL: [http://en.wikipedia.org/w/index.php?title=Euler\\_angles&oldid=436460926](http://en.wikipedia.org/w/index.php?title=Euler_angles&oldid=436460926), 8 pgs.

Electronic Statistics Textbook, StatSoft, Inc., 2011, [online] [retrieved on Jul. 1, 2011] URL: <http://www.statsoft.com/textbook>, 1 pg.

Central Moment, Dec. 16, 2009, [online] [retrieved on Oct. 26, 2010] URL: [http://en.wikipedia.org/w/index.php?title=Central\\_moment&oldid=332048374](http://en.wikipedia.org/w/index.php?title=Central_moment&oldid=332048374).

Local regression, Nov. 16, 2010, [online] [retrieved on Jun. 28, 2011] URL: [http://en.wikipedia.org/w/index.php?title=Local\\_regression&oldid=416762287](http://en.wikipedia.org/w/index.php?title=Local_regression&oldid=416762287).

USPTO Notice of Allowance dated Jun. 6, 2013 issued in U.S. Appl. No. 13/846,830, filed Mar. 18, 2013.

Hernandez-Leon, R., et al., Classifying using Specific Rules with High Confidence, 9th Mexican International Conference on Artificial Intelligence, IEEE, Nov. 2010, pp. 75-80.

Fang, Y., et al., Dynamics of a Winner-Take-All Neural Network, *Neural Networks*, 9(7), Oct. 1996, pp. 1141-1154.

Krueger, M. W., et al., VideoplacE—An Artificial Reality, *Proceeding, CHI '85 Proceedings of the SIGCHI Conference on Human Factors in Computing Systems*, pp. 35-40, ACM New York, NY, USA, Apr. 1985.

Krueger, M. W., ACM Siggraph Touchware, *Pioneers*, [online] [retrieved on Nov. 19, 2013] URL: <http://www.siggraph.org/artdesign/gallery/S98/pione/pione3/krueger.html>, last updated 1999, 1 pg.

VideoplacE, [online] [retrieved on Nov. 19, 2013] URL: <http://en.wikipedia.org/VideoplacE>, last updated Sep. 3, 2013, 1 pg.

Krueger, M., Artmuseum.net, *Pioneers, Responsive 1970*, [online] [retrieved on Nov. 19, 2013] URL: <http://web.archive.org/web/20070929094921/http://www.artmuseum.net/w2vr/timeline/Krueger.html>, Sep. 29, 2007, 1 pg.

Turner, J., Myron Krueger Live, *ctheory.net*, [online] [retrieved on Nov. 19, 2013] <http://www.ctheory.net/articles.aspx?id=328>, Jan. 23, 2002, 8 pgs.

USPTO Notice of Allowance dated Sep. 18, 2013 issued in U.S. Appl. No. 13/786,346, filed Mar. 5, 2013.

USPTO Notice of Allowance dated Sep. 18, 2013 issued in U.S. Appl. No. 13/786,265, filed Mar. 5, 2013.

USPTO Notice of Allowance dated Dec. 6, 2013 issued in U.S. Appl. No. 13/731,946, filed Dec. 31, 2012.

USPTO Notice of Allowance dated Dec. 26, 2013 issued in U.S. Appl. No. 13/549,285, filed Jul. 13, 2012.

USPTO Notice of Allowance dated Feb. 10, 2014 issued in U.S. Appl. No. 13/180,512, filed Jul. 11, 2011.

(56)

## References Cited

## OTHER PUBLICATIONS

- Ronse, C., *Connected Components in Binary Images: The Detection Problem*, John Wiley & Sons Inc. New York, 1984.
- Viberg, M., *Subspace Fitting Concepts in Sensor Array Processing*, Linköping Studies in Science and Technology. Dissertations No. 27 Linköping, Sweden 1989.
- Shapiro, L. S., *Affine Analysis of Image Sequences*, Cambridge University Press, 1995.
- Nara, Y., *Matsushita Demos Multilayer MPEG-4 Compression*, *Electronic Engineering Times*, Apr. 15, 1999 [online] URL: [http://www.eetimes.com/document.asp?doc\\_id=1139149](http://www.eetimes.com/document.asp?doc_id=1139149).
- Moog, R. A., *The Human Finger—A Versatile Electronic Music Instrument Component*, *Audio Engineering Society Preprint*, 1977, New York, NY, 4 pgs.
- Johnson, C., *Image sensor tracks moving objects in hardware*, *Electronic Engineering Times*, Apr. 5, 1999, 1 pg.
- Kaoss pad dynamic effect/controller, *Korg Proview Users' magazine Summer 1999*, 2 pgs.
- Leiberman, D., *Touch screens extend grasp Into consumer realm*, *Electronic Engineering Times*, Feb. 8, 1999.
- Lim, et al., *A Fast Algorithm for Labelling Connected Components in Image Arrays*, Technical Report Series, No. NA86-2, Thinking Machines Corp., 1986 (rev. 1987), Cambridge, Mass., USA, 17 pgs.
- Pennywitt, K., *Robotic Tactile Sensing*, *Byte*, Jan. 1986, 14 pgs.
- Review of Korg X-230 Drum (later called "Wave Drum"), *Electronic Musician*, Apr. 1994, 1 pg.
- Rich, R., *Buchla Lighting MIDI Controller*, *Electronic Musician*, Oct. 1991, 5 pgs.
- Rich, R., *Buchla Thunder*, *Electronic Musician*, Aug. 1990, 4 pgs.
- Dario P., et al., *Tactile sensors and the gripping challenge*, *IEEE Spectrum*, vol. 5, No. 22, Aug. 1985, pp. 46-52.
- Snell, J. M., *Sensors for Playing Computer Music with Expression*, *Proceedings of the Intl. Computer Music Conf. at Eastman*, 1983, pp. 113-126.
- Verner J., *Artif Starr Switch Company Ztar 624-D*, *Electronic Musician*, Nov. 1994, 5 pgs.
- Haken, L., *An Indiscrete Music Keyboard*, *Computer Music Journal*, Spring 1998, pp. 30-48.
- USPTO Notice of Allowance dated May 8, 2013 issued in U.S. Appl. No. 12/541,948, filed Aug. 15, 2009.
- Buxton, W. A. S., *Two-Handed Document Navigation*, *Xerox Disclosure Journal*, 19(2), Mar./Apr. 1994 [online] URL: <http://www.billbuxton.com/2Hnavigation.html>, pp. 103-108.
- USPTO Notice of Allowance dated Mar. 20, 2012 issued in U.S. Appl. No. 12/724,413, filed Mar. 15, 2010.
- USPTO Notice of Allowance dated Jan. 10, 2008 issued in U.S. Appl. No. 10/683,914, filed Oct. 10, 2003.
- USPTO Notice of Allowance dated Nov. 9, 2012 issued in U.S. Appl. No. 12/502,230, filed Jul. 13, 2009.
- USPTO Notice of Allowance dated Mar. 12, 2012 issued in U.S. Appl. No. 12/511,930, filed Jul. 29, 2009.
- USPTO Notice of Allowance dated May 16, 2013 issued in U.S. Appl. No. 13/441,842, filed Apr. 7, 2012.
- USPTO Notice of Allowance dated May 24, 2013 issued in U.S. Appl. No. 13/442,815, filed Apr. 9, 2012.
- USPTO Notice of Allowance dated Dec. 24, 2002 issued in U.S. Appl. No. 09/812,870, filed Mar. 19, 2001.
- Otsu's method, [online] [retrieved on Jun. 26, 2013] URL: [http://en.wikipedia.org/wiki/Otsu\\_method](http://en.wikipedia.org/wiki/Otsu_method), Sep. 13, 2010, 2 pgs.
- Principal component analysis, [online] [retrieved on Jun. 26, 2013] URL: [http://en.wikipedia.org/wiki/Principal\\_component\\_analysis](http://en.wikipedia.org/wiki/Principal_component_analysis), Feb. 25, 2011, 9 pgs.
- USPTO Notice of Allowance dated May 30, 2013 issued in U.S. Appl. No. 13/442,806, filed Apr. 9, 2012.
- DIY Touchscreen Analysis, MOTO, [online] [retrieved on May 12, 2013] URL: <http://labs.moto.com/diy-touchscreen-analysis/>, Jul. 15, 2010, 23 pgs.
- Wilson, T.V., *How the iPhone Works*, *howstuffworks*, [online] [retrieved on May 12, 2013] URL: <http://electronics.howstuffworks.com/iphone2.htm>, Jan. 8, 2011, 11 pgs.
- Walker, G., *Touch and the Apple iPhone*, *Veritas et Visus*, [online] [retrieved on May 12, 2013] URL: <http://www.veritasetvisus.com/VVTP-12.%20Walker.pdf>, Feb. 2007, pp. 50-54.
- Han, J., *Multi-Touch Sensing through LED Matrix Displays* (video), [online] [retrieved on May 12, 2013] "http://cs.nyu.edu/~jhan/ledtouch/index.html," Feb. 18, 2011, 1 pg.
- Roberts Cross, [online] [retrieved on May 12, 2013] URL: [http://en.wikipedia.org/wiki/Roberts\\_Cross](http://en.wikipedia.org/wiki/Roberts_Cross), Jul. 20, 2010, visited Feb. 28, 2011, 3 pgs.
- Sobel Operator, [online] [retrieved on May 12, 2013] URL: [http://en.wikipedia.org/wiki/Sobel\\_operator](http://en.wikipedia.org/wiki/Sobel_operator), Mar. 12, 2010, visited Feb. 28, 2011, 5 pgs.
- Prewitt, [online] [retrieved on May 12, 2013] URL: <http://en.wikipedia.org/wiki/Prewitt>, Mar. 15, 2010, visited Feb. 28, 2011, 2 pgs.
- Coefficient of variation, [online] [retrieved on May 12, 2013] URL: [http://en.wikipedia.org/wiki/Coefficient\\_of\\_variation](http://en.wikipedia.org/wiki/Coefficient_of_variation), Feb. 15, 2010, visited Feb. 28, 2011, 2 pgs.
- Canny edge detector, [online] [retrieved on May 12, 2013] [http://en.wikipedia.org/wiki/Canny\\_edge\\_detector](http://en.wikipedia.org/wiki/Canny_edge_detector), Mar. 5, 2010, 4 pgs.
- Polynomial regression, [online] [retrieved on May 12, 2013] [http://en.wikipedia.org/wiki/Polynomial\\_regression](http://en.wikipedia.org/wiki/Polynomial_regression), Jul. 24, 2010, 4 pgs.
- Pilu, M., et al., *Training PDMs on models: The Case of Deformable Superellipses*, *Proceedings of the 7th British Machine Vision Conference*, Edinburgh, Scotland, 1996, pp. 373-382, [online] [retrieved on Feb. 28, 2011] URL: <https://docs.google.com/viewer=v&pid=explorer&chrome=true&srcid=OBxWzm3JBpMNDI1MDIxZGUtNGZhZi00NzJhLWFhZDMtNTJmYmRiMWYyMjBh&authkey=CPeVx4wO&hl=en>.
- Osian, M., et al., *Fitting Superellipses to Incomplete Contours*, *IEEE Computer Society Conference on Computer Vision and Pattern Recognition Workshops (CVPRW '04)*, Jun. 2004, 8 pgs.
- Hough transform, [online] [retrieved on Feb. 13, 2010] URL: [http://en.wikipedia.org/wiki/Hough\\_transform](http://en.wikipedia.org/wiki/Hough_transform), Feb. 13, 2010, 7 pgs.
- Tactile Pressure Measurement, *Pressure Mapping Systems*, and *Force Sensors and Measurement Systems*, [online] [retrieved on Aug. 6, 2013] URL: <http://www.tekscan.com>, 2 pgs.
- Tactile Surface Pressure and Force Sensors, *Sensor Products LLC*, Oct. 26, 2006, [online] [retrieved on Aug. 6, 2013] URL: <http://www.sensorprod.com>, 2 pgs.
- Pressure Profile Systems, Jan. 29, 2011, [online] [retrieved on Jan. 29, 2011] URL: <http://www.pressureprofile.com>, 1 pg.
- Xsensor Technology Corporation, Feb. 7, 2011, [online] [retrieved on May 12, 2013] URL: <http://www.xsensor.com>, 1 pg.
- Balda AG, Feb. 26, 2011, [online] [retrieved on May 12, 2013] URL: <http://www.balda.de>, 1 pg.
- Cypress Semiconductor, Feb. 28, 2011, [online] [retrieved on May 12, 2013] URL: <http://www.cypress.com>, 1 pg.
- Synaptics, Jan. 28, 2011, [online] [retrieved on May 12, 2013] URL: <http://www.synaptics.com>, 1 pg.
- Venolia, D., et al., *T-Cube: A Fast, Self-Disclosing Pen-Based Alphabet*, *CHI '94 Proceedings of the SIGCHI Conference on Human Factors in Computing Systems*, Apr. 24-28, 1994, pp. 265-270.
- Davis, R. C., et al., *NotePals: Lightweight Note Taking by the Group*, for the Group, University of California, Berkeley, Computer Science Division, 1998, 8 pgs.
- Rekimoto, Jun, *Pick-and-Drop: A Direct Manipulation Technique for Multiple Computer Environments*, *Sony Computer Science Laboratory Inc.*, Tokyo, Japan, 1997, [online] [retrieved on May 30, 2013] URL: <http://www.sonycsll.co.jp/person/rekimoto/papers/ui97.pdf>, 8 pgs.
- Davis, R. C., et al., *NotePals: Lightweight Note Sharing by the Group*, for the Group, [online] [retrieved on Jun. 2, 2013] URL: <http://dub.washington.edu:2007/projects/notepals/pubs/notepals-chi99-final.pdf>, 9 pgs.
- Want, R., et al., *The PARCTAB ubiquitous computing experiment*, 1995-1996, [online] [retrieved on Jun. 10, 2013] URL: <http://www.ece.rutgers.edu/~parashar/Courses/02-03/ece572/perv-reading/the-parctab-ubiquitous-computing.pdf>, 44 pgs.

\* cited by examiner

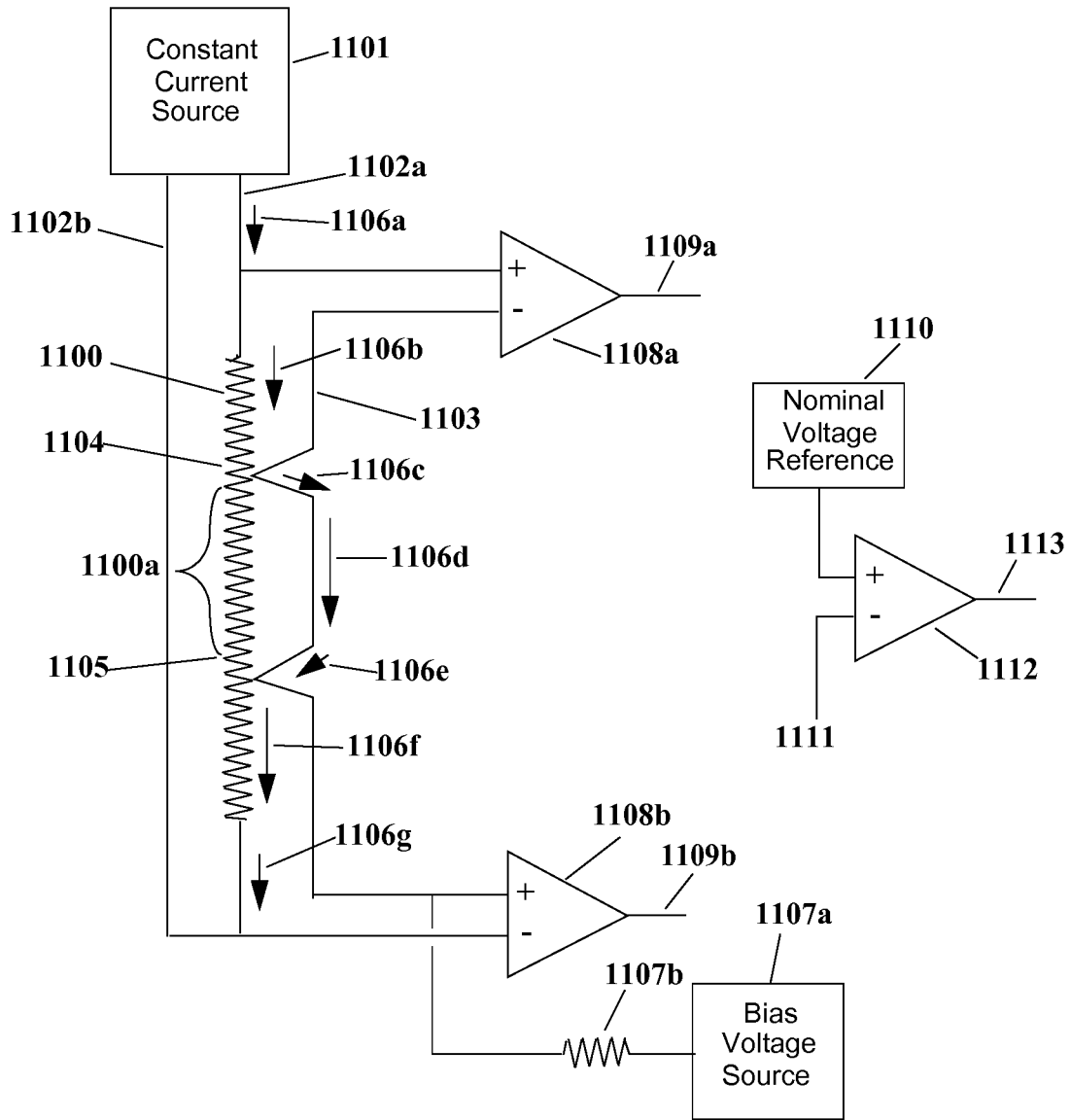

Figure 1

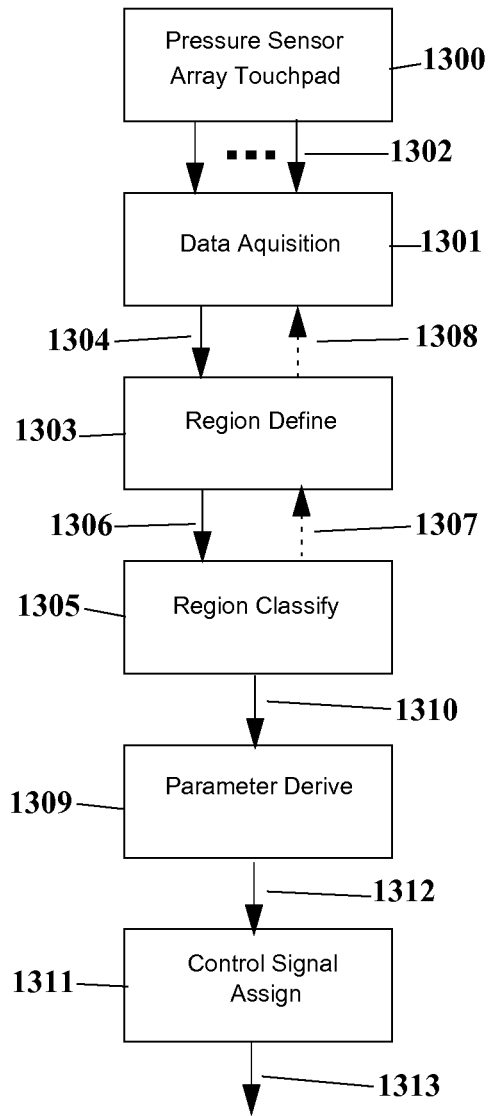

Figure 2

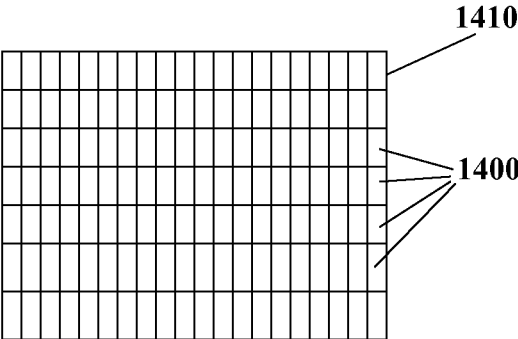

Figure 3

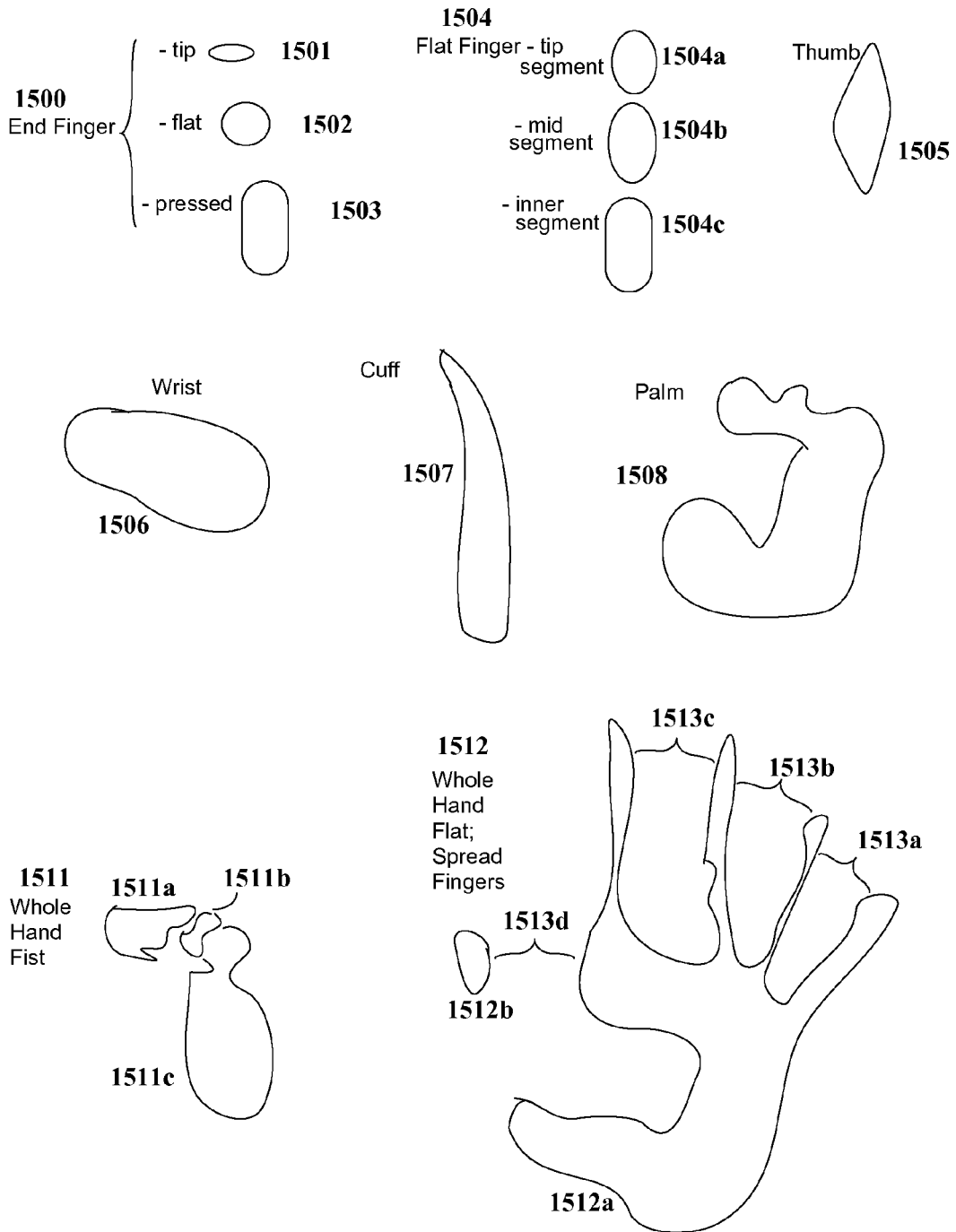

Figure 4



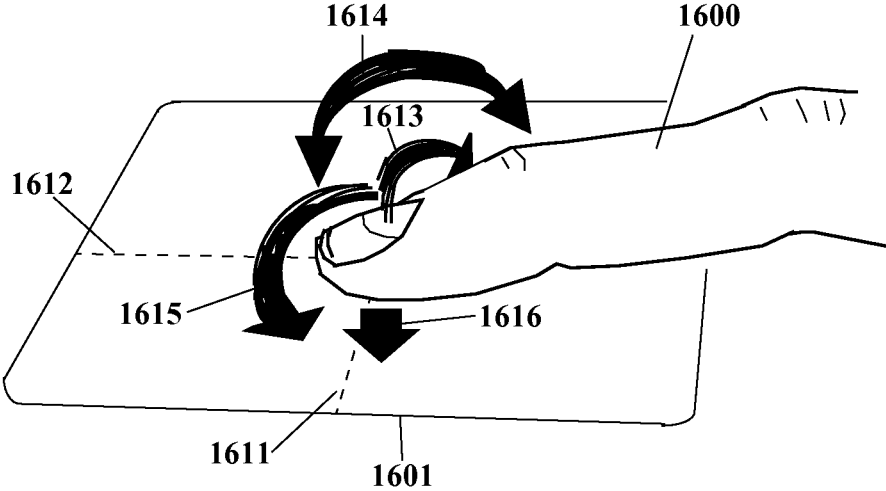

Figure 5

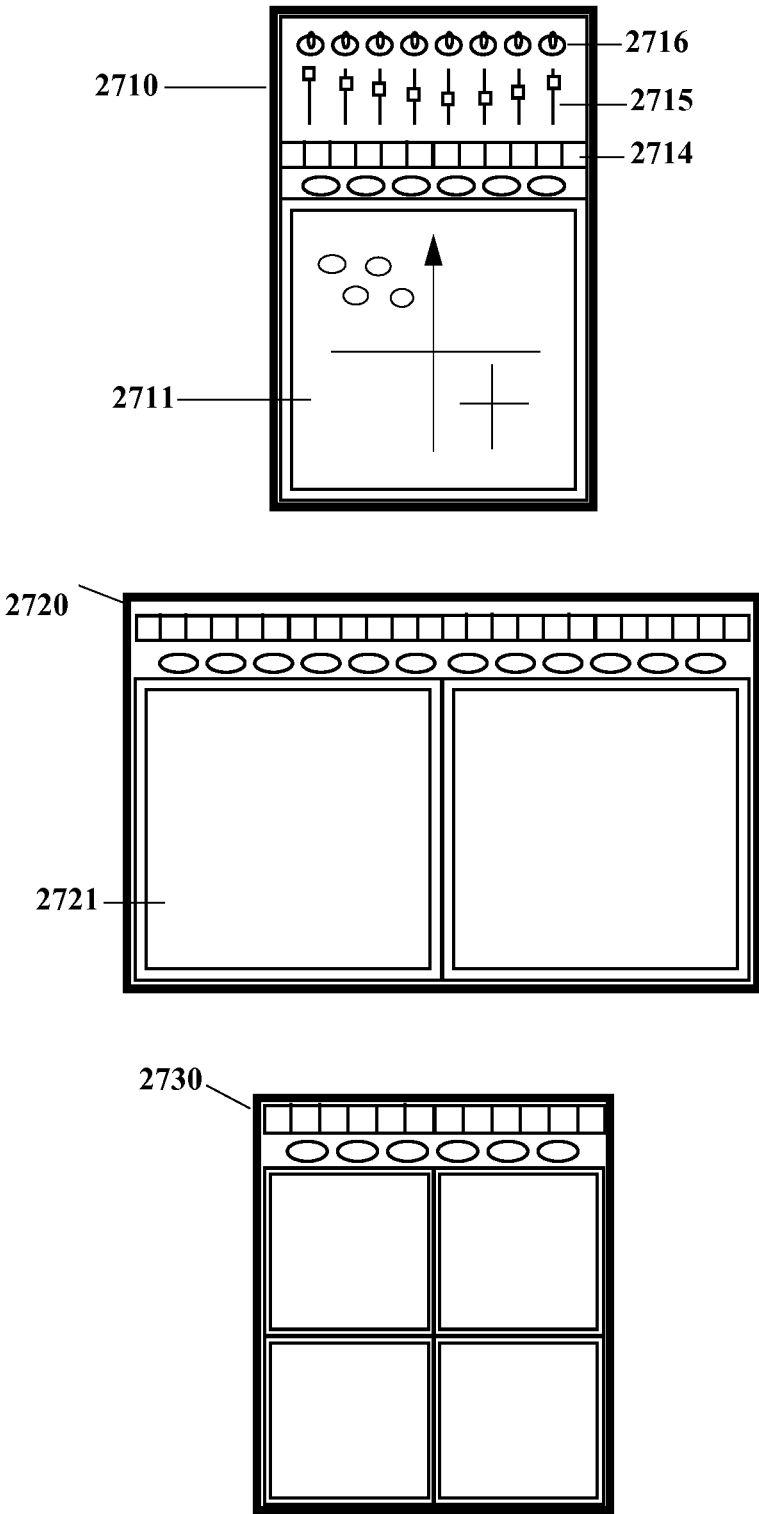

Figure 6

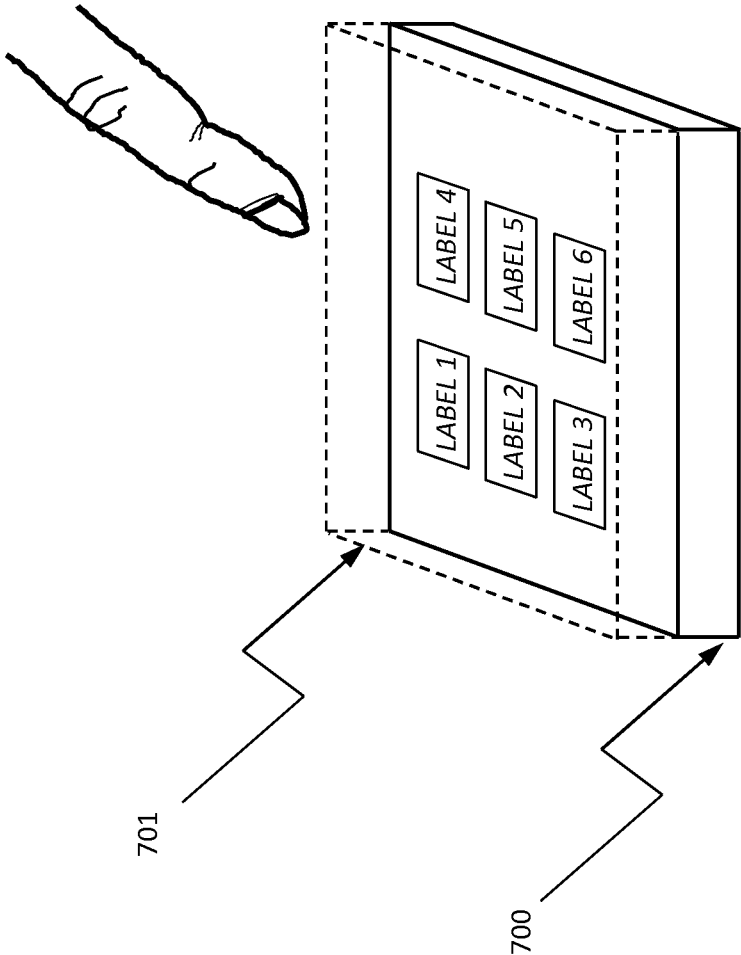

Figure 7

1

**SENSOR ARRAY TOUCHSCREEN  
RECOGNIZING FINGER FLICK GESTURE  
FROM SPATIAL PRESSURE DISTRIBUTION  
PROFILES**

CROSS REFERENCE TO RELATED  
APPLICATIONS

This application is a continuation of U.S. application Ser. No. 11/761,978, filed Jun. 12, 2007, which is a continuation of U.S. application Ser. No. 09/812,400, filed Mar. 19, 2001, now U.S. Pat. No. 7,786,370, issued Aug. 31, 2010, which is a division of U.S. application Ser. No. 09/313,533, filed May 15, 1999, now U.S. Pat. No. 6,610,917, issued Aug. 26, 2003, which claims the benefit of priority of U.S. Provisional Application No. 60/085,713, filed May 15, 1998.

FIELD OF INVENTION

The present invention relates generally to a control system, and in particular, to a tactile input controller for controlling an associated system.

SUMMARY OF THE INVENTION

Touchpad user interfaces for controlling external systems such as computers, machinery, and process environments via at least three independent control signals. The touchpad may be operated by hand, other parts of the body, or inanimate objects. Such an interface affords a wide range of uses in computer applications, machine and process control, and assistance to the disabled. In one embodiment simple contact position-sensing touchpads, producing control signals responsive to a contact region, are enhanced to provide several independent control signals. Enhancements may include velocity sensors, pressure sensors, and electronic configurations measuring contact region widths. Touch-screens positioned over visual displays may be adapted. According to other aspects pressure-sensor array touchpads are combined with image processing to responsively calculate parameters from contact regions. Six independent control parameters can be derived from each region of contact. These may be easily manipulated by a user. In one implementation, smaller pressure-sensor arrays are combined with data acquisition and processing into a chip that can be tiled in an array.

DESCRIPTION OF THE DRAWINGS

The above and other aspects, features and advantages of the present invention will become more apparent upon consideration of the following description of preferred embodiments taken in conjunction with the accompanying drawing figures, wherein:

FIG. 1 shows an example of how two independent contact points can be independently discerned, or the dimensional-width of a single contact point can be discerned, for a resistance null/contact controller with a single conductive contact plate or wire and one or more resistive elements whose resistance per unit length is a fixed constant through each resistive element;

FIG. 2 shows how a pressure-sensor array touch-pad can be combined with image processing to assign parameterized interpretations to measured pressure gradients and output those parameters as control signals;

FIG. 3 illustrates the positioning and networking of pressure sensing and processing "mini-array" chips in larger contiguous structures;

2

FIG. 4 illustrates the pressure profiles for a number of example hand contacts with a pressure-sensor array;

FIG. 5 illustrates how six degrees of freedom can be recovered from the contact of a single finger; and

FIG. 6 illustrates examples of single, double, and quadruple touch-pad instruments with pads of various sizes and supplemental instrument elements.

FIG. 7 illustrates an example implementation involving dynamically assigned labels.

DETAILED DESCRIPTION

Overview

Described herein are two kinds of novel touch-pads. Null/contact touchpads are contact-position sensing devices that normally are in a null state unless touched and produce a control signal when touched whose signal value corresponds to typically one unique position on the touch-pad. A first enhancement is the addition of velocity and/or pressure sensing. A second enhancement is the ability to either discern each dimensional-width of a single contact area or, alternatively, independently discern two independent contact points in certain types of null/contact controllers. A third possible enhancement is that of employing a touch-screen instance of null/contact touch pad and positioning it over a video display.

The invention also provides for a pressure-sensor array touch-pad. A pressure-sensor array touch-pad of appropriate sensitivity range, appropriate "pixel" resolution, and appropriate physical size is capable of measuring pressure gradients of many parts of the human hand or foot simultaneously. A pressure-sensor array touch-pad can be combined with image processing to assign parameterized interpretations to measured pressure gradients and output those parameters as control signals. The pressure-sensor "pixels" of a pressure-sensor array are interfaced to a data acquisition stage; the data acquisition state looks for sensor pixel pressure measurement values that exceed a low-level noise-rejection/deformity-reject threshold; contiguous regions of sufficiently high pressure values are defined; the full collection of region boundaries are subjected to classification tests; various parameters are derived from each independent region; and these parameters are assigned to the role of specific control signals which are then output to a signal routing, processing, and synthesis entity.

It is possible to derive a very large number of independent control parameters which are easily manipulated by the operating user. For example, six degrees of freedom can be recovered from the contact of a single finger. A whole hand posture can yield 17 instantaneously and simultaneously measurable parameters which are independently adjustable per hand. The recognized existence and/or derived parameters from postures and gestures may be assigned to specific outgoing control signal formats and ranges. The hand is used throughout as an example, but it is understood that the foot or even other body regions, animal regions, objects, or physical phenomena can replace the role of the hand.

It will be evident to one of ordinary skill in the art that it is advantageous to have large numbers of instantaneously and simultaneously measurable parameters which are independently adjustable. For instance, a symbol in a 2-D CAD drawing can be richly interactively selected and installed or edited in moments as opposed to tens to hundreds of seconds as is required by mouse manipulation of parameters one or two at a time and the necessary mode-changes needed to change the mouse action interpretation. As a result, said touch-pad has applications in computer workstation control,

general real-time machine control, computer data entry, and computer simulation environments.

Various hardware implementations are possible. A particularly advantageous implementation would be to implement a small pressure-sensor array together with data acquisition and a small processor into a single chip package that can be laid as tiles in a larger array.

#### Null/Contact Touch-Pads

Distinguished from panel controls and sensors are what will be termed null/contact touch-pads. This is a class of contact-position sensing devices that normally are in a null state unless touched and produce a control signal when touched whose signal value corresponds to typically one unique position on the touch-pad. Internal position sensing mechanisms may be resistive, capacitive, optical, standing wave, etc. Examples of these devices include one-dimensional-sensing ribbon controllers found on early music synthesizers, two-dimensional-sensing pads such as the early Kawala pad and more modern mini-pads found on some lap-top computers, and two-dimensional-sensing see-through touch-screens often employed in public computer kiosks.

The null condition, when the pad is untouched, requires and/or provides the opportunity for special handling. Some example ways to handle the untouched condition include:

- sample-hold (hold values issued last time sensor was touched, as does a joystick)

- bias **1107a**, **1107b** (issue maximal-range value, minimal-range value, mid-range value, or other value)

- touch-detect on another channel (i.e., a separate out-of-band "gate" channel).

Additional enhancements can be added to the adaptation of null/contact touch-pad controllers as instrument elements. A first enhancement is the addition of velocity and/or pressure sensing. This can be done via global impact and/or pressure sensors. An extreme of this is implementation of the null/contact touch-pad controller as a pressure-sensor array; this special case and its many possibilities are described later.

A second enhancement is the ability to either discern each dimensional-width of a single contact area or, alternatively, independently discern two independent contact points in certain types of null/contact controllers. FIG. 1 shows an example of how two independent contact points can be independently discerned, or the dimensional-width of a single contact point can be discerned, for a resistance null/contact controller with a single conductive contact plate (as with the Kawala pad product) or wire (as in some types of ribbon controller products) and one or more resistive elements **1100** whose resistance per unit length is a fixed constant through each resistive element. It is understood that a one-dimensional null/contact touch-pad typically has one such resistive element while a two-dimensional null/contact touch-pad typically has two such resistive elements that operate independently in each direction.

Referring to FIG. 1, a constant current source **1101** can be applied to the resistive element as a whole **1102a-1102b**, developing a fixed voltage across the entire resistive element **1100**. When any portion of the resistive element is contacted by either a non-trivial contiguous width and/or multiple points of contact **1104-1105**, part of the resistive element is shorted out **1100a**, thus reducing the overall width-to-end resistance of the resistance element. Because of the constant current source **1101**, the voltage developed across the entire resistive element **1102a-1102b** drops by an amount equal to the portion of the resistance that is shorted out.

The value of the voltage drop then equals a value in proportion to the distance separating the extremes of the wide

and/or multiple contact points **1104-1105**. By subtracting **1111**, **1112**, **1113** the actual voltage across the entire resistive element from the value this voltage is normally **1110**, a control voltage proportional to distance separating the extremes of the wide and/or multiple contact points **1104-1105** is generated. Simultaneously, the voltage difference between that of the contact plate/wire **1103** and that of the end of the resistive element closest to an external contact point **1102a** or **1102b** is still proportional to the distance from said end to said external contact point. Using at most simple op-amp summing and/or differential amplifiers **1108a**, **1108b**, **1112**, a number of potential control voltages can be derived; for example one or more of these continuously-valued signals:

- value of distance difference between external contact points (or "width"; as described above via constant current source, nominal reference voltage, and differential amplifier **1113**)

- center of a non-trivial-width region (obtained by simple averaging, i.e., sum with gain of  $\frac{1}{2}$ )

- value of distance difference **1109a** between one end of the resistive element and the closest external contact point (simple differential amplifier)

- value of distance difference between the other end of the resistive element and the other external contact point (sum above voltage with "width" voltage with appropriate sign) **1109b**.

Further, through use of simple threshold comparators, specific thresholds of shorted resistive element can be deemed to be, for example, any of a single point contact, a recognized contact region width, two points of contact, etc., producing corresponding discrete-valued control signals. The detection of a width can be treated as a contact event for a second parameter analogous to the single contact detection event described at the beginning. Some example usages of these various continuous and discrete signals are:

- existence of widths or multiple contact points may be used to trigger events or timbre changes

- degree of widths may be used to control degrees of modulation or timbre changes

- independent measurement of each external contact point from the same end of the resistive element can be used to independently control two parameters. In the simplest form, one parameter is always larger than another; in more complex implementations, the trajectories of each contact point can be tracked (using a differentiator and controlled parameter assignment switch); as long as they never simultaneously touch, either parameter can vary and be larger or smaller than the other.

It is understood that analogous approaches may be applied to other null/contact touchpad technologies such as capacitive or optical.

A third possible enhancement is that of employing a touch-screen instance of null/contact touch-pad and positioning it over a video display. The video display could for example provide dynamically assigned labels, abstract spatial cues, spatial gradients, line-of-site cues for fixed or motor-controlled lighting, etc. which would be valuable for use in conjunction with the adapted null/contact touch-pad controller.

These various methods of adapted null/contact touch-pad elements can be used stand-alone or arranged in arrays. In addition, they can be used as a component or addendum to instruments featuring other types of instrument elements. Pressure-Sensor Array Touch-Pads

The invention provides for use of a pressure-sensor array arranged as a touch-pad together with associated image processing. As with the null/contact controller, these pressure-

5

sensor array touch-pads may be used stand-alone or organized into an array of such pads.

It is noted that the inventor's original vision of the below described pressure-sensor array touch-pad was for applications not only in music but also for computer data entry, computer simulation environments, and real-time machine control, applications to which the below described pressure-sensor array touch-pad clearly can also apply.

A pressure-sensor array touch-pad of appropriate sensitivity range, appropriate "pixel" resolution, and appropriate physical size is capable of measuring pressure gradients of many parts of the flexibly-rich human hand or foot simultaneously. FIG. 2 shows how a pressure sensor array touch-pad can be combined with image processing to assign parameterized interpretations to measured pressure gradients and output those parameters as control signals.

The pressure-sensor "pixels" of a pressure-sensor array touch-pad **1300** are interfaced to a data acquisition stage **1301**. The interfacing method may be fully parallel but in practice may be advantageously scanned at a sufficiently high rate to give good dynamic response to rapidly changing human touch gestures. To avoid the need for a buffer amplifier for each pressure-sensor pixel, electrical design may carefully balance parasitic capacitance of the scanned array with the electrical characteristics of the sensors and the scan rates; electrical scanning frequencies can be reduced by partitioning the entire array into distinct parts that are scanned in parallel so as to increase the tolerance for address settling times and other limiting processes.

Alternatively, the pressure-sensor array **1300** may be fabricated in such a way that buffer amplifier arrays can be inexpensively attached to the sensor array **1300**, or the sensors may be such that each contains its own buffer amplifier; under these conditions, design restrictions on scanning can be relaxed and operate at higher speeds. Although the pressure sensors may be likely analog in nature, a further enhancement would be to use digital-output pressure-sensor elements or sub-arrays.

The data acquisition stage **1301** looks for sensor pixel pressure measurement values that exceed a low-level noise-rejection/deformity-rejection threshold. The sufficiently high pressure value of each such sensor pixel is noted along with the relative physical location of that pixel (known via the pixel address). This noted information may be stored "raw" for later processing and/or may be subjected to simple boundary tests and then folded into appropriate running calculations as will be described below. In general, the pressure values and addresses of sufficiently high pressure value pixels are presented to a sequence of processing functions which may be performed on the noted information:

contiguous regions of sufficiently high pressure values are defined (a number of simple run-time adjacency tests can be used; many are known—see for example [Ronse; Viberg; Shapiro; Hara])

the full collection of region boundaries are subjected to classification tests; in cases a given contiguous region may be split into a plurality of tangent or co-bordered independently recognized regions

various parameters are derived from each independent region, for example geometric center, center of pressure, average pressure, total size, angle-of-rotation-from-reference for non-round regions, second-order and higher-order geometric moments, second-order and higher-order pressure moments, etc.

assignment of these parameters to the role of specific control signals (note events, control parameters, etc.) which

6

are then output to a signal routing, processing, and synthesis entity; for example, this may be done in the form of MIDI messages.

Because of the number of processes involved in such a pipeline, it is advantageous to follow a data acquisition stage **1301** with one or more additional processing stages **1303**, **1305**, **1309**, and **1311**. Of the four example processing functions just listed, the first three fall in the character of image processing. It is also possible to do a considerable amount of the image processing steps actually within the data acquisition step, namely any of simple adjacency tests and folding selected address and pressure measurement information into running sums or other running pre-calculations later used to derive aforementioned parameters. The latter method can be greatly advantageous as it can significantly collapse the amount of data to be stored.

Regardless of whether portions of the image processing are done within or beyond the data acquisition stage, there are various hardware implementations possible. One hardware approach would involve very simple front-end scanned data acquisition hardware and a single high-throughput microprocessor/signal-processor chip. Alternatively, an expanded data acquisition stage may be implemented in high-performance dedicated function hardware and this would be connected to a lower performance processor chip. A third, particularly advantageous implementation would be to implement a small pressure-sensor array together with data acquisition and a small processor into a single low-profile chip package that can be laid as tiles in a nearly seamless larger array. In such an implementation all image processing could in fact be done via straightforward partitions into message-passing distributed algorithms.

One or more individual chips could direct output parameter streams to an output processor which would organize and/or assign parameters to output control channels, perhaps in a programmable manner under selectable stored program control. A tiled macro array of such "sensor mini-array" chips could be networked by a tapped passive bus, one- or two-dimensional mode active bus daisy-chain, a potentially expandable star-wired centralized message passing chip or subsystem, or other means.

Creating a large surface from such "tile chips" will aid in the serviceability of the surface. Since these chips can be used as tiles to build a variety of shapes, it is therefore possible to leverage a significant manufacturing economy-of-scale so as to minimize cost and justify more extensive feature development. Advanced seating and connector technologies, as used in laptops and other high-performance miniature consumer electronics, can be used to minimize the separation between adjacent chip "tiles" and resultant irregularities in the tiled-surface smoothness. A tiled implementation may also include a thin rugged flexible protective film that separates the sensor chips from the outside world. FIG. 3 illustrates the positioning and networking of pressure sensing and processing "mini-array" chips **1400** in larger contiguous structures **1410**.

With the perfection of a translucent pressure-sensor array, it further becomes possible for translucent pressure-sensor arrays to be laid atop aligned visual displays such as LCDs, florescent, plasma, CRTs, etc. as was discussed above for null/contact touch-pads. The displays can be used to label areas of the sensor array, illustrate gradients, etc. FIG. 7 illustrates an example implementation involving dynamically assigned labels on a video display **700** for use in conjunction with a transparent touch-screen **701**. Note that in the "tile chip" implementation, monochrome or color display areas may indeed be built into each chip.

Returning now to the concept of a pressure-sensor array touch-pad large enough for hand-operation: examples of hand contact that may be recognized, example methods for how these may be translated into control parameters, and examples of how these all may be used are now described. In the below the hand is used throughout as an example, but it is understood that the foot or even other body regions, animal regions, objects, or physical phenomena can replace the role of the hand in these illustrative examples.

FIG. 4 illustrates the pressure profiles for a number of example hand contacts with a pressure-sensor array. In the case 1500 of a finger's end, pressure on the touch-pad pressure-sensor array can be limited to the finger tip, resulting in a spatial pressure distribution profile 1501; this shape does not change much as a function of pressure. Alternatively, the finger can contact the pad with its flat region, resulting in light pressure profiles 1502 which are smaller in size than heavier pressure profiles 1503. In the case 1504 where the entire finger touches the pad, a three-segment pattern (1504a, 1504b, 1504c) will result under many conditions; under light pressure a two segment pattern (1504b or 1504c missing) could result. In all but the lightest pressures the thumb makes a somewhat discernible shape 1505 as do the wrist 1506, cuff 1507, and palm 1508; at light pressures these patterns thin and can also break into disconnected regions. Whole hand patterns such as the first 1511 and flat hand 1512 have more complex shapes. In the case of the first 1511, a degree of curl can be discerned from the relative geometry and separation of sub-regions (here depicted, as an example, as 1511a, 1511b, and 1511c). In the case of the whole flat hand 1512, there can be two or more sub-regions which may be in fact joined (as within 1512a) and/or disconnected (as an example, as 1512a and 1512b are); the whole hand also affords individual measurement of separation "angles" among the digits and thumb (1513a, 1513b, 1513c, 1513d) which can easily be varied by the user.

Relatively simple pattern recognition software can be used to discern these and other hand contact patterns which will be termed "postures." The pattern recognition working together with simple image processing may, further, derive a very large number of independent control parameters which are easily manipulated by the operating user. In many cases it may be advantageous to train a system to the particulars of a specific person's hand(s) and/or specific postures. In other situations the system may be designed to be fully adaptive and adjust to a person's hand automatically. In practice, for the widest range of control and accuracy, both training and ongoing adaptation may be useful. Further, the recognized postures described thus far may be combined in sequence with specific dynamic variations among them (such as a finger flick, double-tap, etc.) and as such may be also recognized and thus treated as an additional type of recognized pattern; such sequential dynamics among postures will be termed "gestures."

The admission of gestures further allows for the derivation of additional patterns such as the degree or rate of variation within one or more of the gesture dynamics. Finally, the recognized existence and/or derived parameters from postures and gestures may be assigned to specific outgoing control signal formats and ranges. Any training information and/or control signal assignment information may be stored and recalled for one or more players via stored program control.

For each recognized pattern, the amount of information that can be derived as parameters is in general very high. For the human hand or foot, there are, typically, artifacts such as shape variation due to elastic tissue deformation that permit

recovery of up to all six degrees of freedom allowed in an object's orientation in 3-space.

FIG. 5 illustrates how six degrees of freedom can be recovered from the contact of a single finger. In the drawing, the finger 1600 makes contact with the touch-pad 1601 with its end segment at a point on the touch-pad surface determined by coordinates 1611 and 1612 (these would be, for example, left/right for 1611 and forward/backward for 1612). Fixing this point of contact, the finger 1600 is also capable of rotational twisting along its length 1613 as well as rocking back and forth 1614. The entire finger can also be pivoted with motion 1615 about the contact point defined by coordinates 1611 and 1612. These are all clearly independently controlled actions, and yet it is still possible in any configuration of these thus far five degrees of freedom, to vary the overall pressure 1616 applied to the contact point. Simple practice, if it is even needed, allows the latter overall pressure 1616 to be independently fixed or varied by the human operator as other parameters are adjusted.

In general other and more complex hand contacts, such as use of two fingers, the whole hand, etc. forfeit some of these example degrees of freedom but often introduce others. For example, in the quite constrained case of a whole hand posture, the fingers and thumb can exert pressure independently (5 parameters), the finger and thumb separation angles can be varied (4 parameters), the finger ends 1504a can exert pressure independently from the middle 1504b and inner 1504c segments (4 parameters), the palm can independently vary its applied pressure (1 parameter) while independently tilting/rocking in two directions (2 parameters) and the thumb can curl (1 parameter), yielding 17 instantaneously and simultaneously measurable parameters which are independently adjustable per hand. Complex contact postures may also be viewed as, or decomposed into, component sub-postures (for example here, as flat-finger contact, palm contact, and thumb contact) which would then derive parameters from each posture independently. For such complex contact postures, recognition as a larger compound posture which may then be decomposed allows for the opportunity to decouple and/or renormalize the parameter extraction in recognition of the special affairs associated with and constraints imposed by specific complex contact postures.

It is noted that the derived parameters may be pre-processed for specific uses. One example of this would be the quantization of a parameter into two or more discrete steps; these could for example be sequentially interpreted as sequential notes of a scale or melody. Another example would be that of warping a parameter range as measured to one with a more musically expressive layout.

Next examples of the rich metaphorical aspects of interacting with the pressure sensor array touch-pad are illustrated. In many cases there may be one or more natural geometric metaphor(s) applicable, such as associating left-right position, left-right twisting, or left-right rotation with stereo panning, or in associating overall pressure with volume or spectral complexity. In more abstract cases, there may be pairs of parameters that go together—here, for example with a finger end, it may be natural to associate one parameter pair with (left/right and forward/backward) contact position and another parameter pair with (left/right and forward/backward) twisting/rocking. In this latter example there is available potential added structure in the metaphor by viewing the twisting/rocking plane as being superimposed over the position plane. The superposition aspect of the metaphor can be viewed as an index, or as an input-plane/output-plane distinction for a two-input/two-output transformation, or as two separated processes which may be caused to converge or

morph according to additional overall pressure, or in conjunction with a dihedral angle of intersection between two independent processes, etc.

Next, examples of the rich syntactical aspects of interacting with the pressure-sensor array touch-pad are illustrated. Some instruments have particular hand postures naturally associated with their playing. It is natural then to recognize these classical hand-contact postures and derive control parameters that match and/or transcend how a classical player would use these hand positions to evoke and control sound from the instrument. Further, some postures could be recognized either in isolation or in gestural-context as being ones associated with (or assigned to) percussion effects while remaining postures may be associated with accompanying melodies or sound textures.

As an additional syntactic aspect, specific hand postures and/or gestures may be mapped to specific selected assignments of control signals in ways affiliated with specific purposes. For example, finger ends may be used for one collection of sound synthesis parameters, thumb for a second potentially partially overlapping collection of sound synthesis parameters, flat fingers for a third partially-overlapping collection, wrist for a fourth, and cuff for a fifth, and first for a sixth. In this case it may be natural to move the hand through certain connected sequences of motions; for example: little finger end, still in contact, dropping to flat-finger contact, then dropping to either palm directly or first to cuff and then to palm, then moving to wrist, all never breaking contact with the touch-pad. Such permissible sequences of postures that can be executed sequentially without breaking contact with the touch-pad will be termed "continuous grammars."

Under these circumstances it is useful to set up parameter assignments, and potentially associated context-sensitive parameter renormalizations, that work in the context of selected (or all available) continuous grammars. For example, as the hand contact evolves as being recognized as one posture and then another, parameters may be smoothly handed-over in interpretation from one posture to another without abrupt changes, while abandoned parameters either hold their last value or return to a default value (instantly or via a controlled envelope).

Now a number of example applications of the pressure-sensor array touchpad are provided. It is known to be possible and valuable to use the aforementioned pressure-sensor array touch-pad, implicitly containing its associated data acquisition, processing, and assignment elements, for many, many applications such as general machine control and computer workstation control. One example of machine control is in robotics: here a finger might be used to control a hazardous material robot hand as follows:

left/right position: left/right hand position  
 in/out position: in/out hand position  
 in/out rock: up/down hand position  
 rotation: hand grip approach angle  
 overall pressure: grip strength  
 left/right twist: gesture to lock or release current grip from pressure control

A computer workstation example may involve a graphical Computer-Aided Design application currently requiring intensive mouse manipulation of parameters one or two at a time:

left/right position: left/right position of a selected symbol in a 2-D CAD drawing  
 in/out position: up/down position of a selected symbol in 2-D CAD drawing  
 left/right twist: symbol selection—left/right motion through 2-D palette

in/out rock: symbol selection—up/down motion through 2-D palette  
 rotation: rotation of selected symbol in the drawing  
 overall pressure: sizing by steps  
 tap of additional finger: lock selection into drawing or unlock for changes  
 tap of thumb: undo  
 palm: toggle between add new object and select existing object

Clearly a symbol can be richly interactively selected and installed or edited in moments as opposed to tens to hundreds of seconds as is required by mouse manipulation of parameters one or two at a time and the necessary mode-changes needed to change the mouse action interpretation.

#### 15 Touch-Pad Array

Touch-pad instrument elements, such as null/contact types and pressure-sensor array types described earlier, can be used in isolation or arrays to create electronic controller instruments. The touch-pad(s) may be advantageously supplemented with panel controls such as push buttons, sliders, knobs as well as impact sensors for velocity-controlled triggering of percussion or pitched note events. If one or more of the touch-pads is transparent (as in the case of a null/contact touch screen overlay) one or more video, graphics, or alphanumeric displays **2711** may be placed under a given pad or group of pads.

FIG. 6 illustrates examples of single **2710**, double **2720**, and quadruple **2730** touchpad instruments with pads of various sizes. A single touch-pad could serve as the central element of such an instrument, potentially supplemented with panel controls such as push buttons **2714**, sliders **2715**, knobs **2716** as well as impact sensors. In FIG. 6, a transparent pad superimposed over a video, graphics, or one or more alphanumeric displays is assumed, and specifically shown is a case of underlay graphics cues being displayed for the player. Two large sensors can be put side by side to serve as a general purpose left-hand/right-hand multi-parameter controller.

All publications and patent applications mentioned in this specification are herein incorporated by reference to the same extent as if each individual publication or patent application was specifically and individually indicated to be incorporated by reference. The invention now being fully described, it will be apparent to one of ordinary skill in the art that many changes and modifications can be made thereto without departing from its spirit or scope.

#### REFERENCES CITED

The following references are cited in this patent application using the format of the first one or two authors last name(s) within square brackets "[ ]", multiple references within a pair of square brackets separated by semicolons ";;"

[Ronse] Ronse, Christian and Devijver, Pierre A., *Connected Components in Binary Images: the Detection Problem*, John Wiley & Sons Inc. New York, 1984;

[Viberg] Viberg, Mats, *Subspace Fitting Concepts in Sensor Array Processing*, Linkoping Studies in Science and Technology. Dissertations No. 27 Linkoping, Sweden 1989;

[Shapiro] Shapiro, Larry S., *Affine Analysis of Image Sequences*, Cambridge University Press, 1995;

[Hara] Hara, Yoshiko "Matsushita demos multilayer MPEG-4 compression", *Electronic Engineering Times*, Apr. 19, 1999.

The invention claimed is:

1. An apparatus comprising:  
 a transparent touchpad positioned over a visual display, the transparent touchpad configured to sense a contiguous



11

region of contact from at least a portion of a human hand on a surface of the transparent touchpad, the transparent touch pad comprising a sensor array having a plurality of sensors, each sensor having a unique spatial location and an associated unique address, wherein the transparent touch pad is configured to sense the contiguous region of contact by a generation of sensor measurement values associated with each of the plurality of sensors, wherein a plurality of sensor spatial locations are configured to provide associated sensor measurement values responsive to the contiguous region of contact;

a value of at least one control parameter for the contiguous region of contact responsive to a measured change in at least one of the associated sensor measurement values, the value obtained by performing a calculation on the associated sensor measurement values and interpreting the results as signifying a finger flick touch gesture, wherein the at least one control parameter is associated with the finger flick touch gesture; and

at least one derived control parameter assigned to a specific control signal;

wherein the finger flick touch gesture is recognized from sequential dynamics among postures derived from spatial pressure distribution profiles.

2. The apparatus of claim 1 wherein the transparent touch pad is configured to sense the contiguous region of contact by determining the pressure values and coordinates for selected pixels associated with the portion of the human hand on the surface of the transparent touchpad.

3. The apparatus of claim 1, wherein the transparent touch pad is configured to determine the sequential dynamics among postures based on a pattern for the contiguous region of contact.

4. The apparatus of claim 1, wherein the transparent touch pad is configured to sense the contiguous region of contact by a generation of the associated sensor measurement values based on identifying a point of contact for the sensed region of contact relative to the surface of the transparent touchpad.

5. The apparatus of claim 1, wherein the transparent touchpad is configured to sense the contiguous region of contact by a generation of the associated sensor measurement values based on identifying measurement values that exceed a threshold.

6. The apparatus of claim 1, wherein the transparent touch pad is further configured to track a trajectory of movement of the portion of the human hand contacting the surface of the transparent touchpad.

7. The apparatus of claim 1, wherein the visual display is further configured to provide dynamically assigned labels.

8. The apparatus of claim 1, wherein at least one control parameter is responsive to a geometric center of the contiguous region of measurement values.

9. The apparatus of claim 1, wherein at least one control parameter is responsive to a center of pressure of the contiguous region of measurement values.

12

10. The apparatus of claim 1, wherein at least one control parameter is responsive to an average pressure of the contiguous region of measurement values.

11. The apparatus of claim 1, wherein at least one control parameter is responsive to a total size of the contiguous region of measurement values.

12. The apparatus of claim 1, wherein the transparent touch pad is further configured to sense at least a second contiguous region of contact from another portion of a human hand on a surface of the transparent touchpad, and the apparatus is configured to derive a value of at least another control parameter responsive the second contiguous region of contact.

13. An apparatus comprising:

a transparent touch sensor array comprising a plurality of transparent sensors positioned over a display associated with the apparatus to form a transparent touchpad, wherein the transparent touch sensor array is configured to sense contact with one or more fingers on a corresponding contiguous region on the transparent touch pad, wherein each transparent sensor of the plurality of transparent sensors has a corresponding spatial location, associated address, and is configured to provide associated sensor measurement values;

at least one control parameter associated with a finger flick touch gesture, the finger flick touch gesture recognized from sequential dynamics among postures derived from spatial pressure distribution profiles and associated with a measured change to at least one of the associated sensor measurement values; and

at least one control signal associated with the at least one control parameter; and

wherein the finger flick touch gesture corresponds to one or more interactions with displayed visual content of an application operating on the apparatus.

14. The apparatus of claim 13, wherein the postures are associated with a single continuous touching of the transparent touch sensor array.

15. The apparatus of claim 13, wherein the display is configured to dynamically provide at least one label at a corresponding spatial location of at least one of the plurality for transparent sensors in response to the control signals.

16. The apparatus of claim 13, wherein the display is configured to control displayed visual content based on controlling at least one of a selection, a motion, and a sizing of the displayed visual content.

17. The apparatus of claim 13, wherein the spatial pressure distribution profiles consist of one or more shapes of hand contact patterns.

18. The apparatus of claim 13, further comprising at least one control parameter associated with another touch gesture, the another touch gesture recognized from sequential dynamics among postures derived from spatial pressure distribution profiles and associated with a measured change to at least one of the associated sensor measurement values.

\* \* \* \* \*