



(12) **United States Patent**  
**Ludwig**

(10) **Patent No.:** **US 9,304,677 B2**  
(45) **Date of Patent:** **\*Apr. 5, 2016**

(54) **TOUCH SCREEN APPARATUS FOR RECOGNIZING A TOUCH GESTURE** USPC ..... 345/173-178; 178/18.01-18.08  
See application file for complete search history.

(75) Inventor: **Lester F. Ludwig**, San Antonio, TX (US)

(56) **References Cited**

(73) Assignee: **Advanced Touchscreen and Gestures Technologies, LLC**, San Antonio, TX (US)

U.S. PATENT DOCUMENTS

1,947,020 A 2/1934 Howland  
3,493,669 A 2/1970 Elbrecht et al.

(Continued)

(\* ) Notice: Subject to any disclaimer, the term of this patent is extended or adjusted under 35 U.S.C. 154(b) by 747 days.  
This patent is subject to a terminal disclaimer.

FOREIGN PATENT DOCUMENTS

EP 0609021 8/1994  
EP 0689122 12/1995

(Continued)

(21) Appl. No.: **13/473,525**

OTHER PUBLICATIONS  
USPTO Non-Final Office Action dated Jan. 23, 2012 issued in U.S. Appl. No. 12/418,605, filed Apr. 5, 2009.

(22) Filed: **May 16, 2012**

(Continued)

(65) **Prior Publication Data**

US 2012/0235940 A1 Sep. 20, 2012

**Related U.S. Application Data**

(60) Continuation of application No. 11/761,978, filed on Jun. 12, 2007, now Pat. No. 8,717,303, which is a continuation of application No. 09/812,400, filed on Mar. 19, 2001, now Pat. No. 7,786,370, which is a  
(Continued)

*Primary Examiner* — Premal Patel

(74) *Attorney, Agent, or Firm* — Beck Tysver Evans PLLC

(57) **ABSTRACT**

A touch-based user interface system comprising an arrangement for scanning a tactile sensor array to produce a corresponding array of measurement values that are presented to a processor for computation. The computation produces a plurality of running sums created from selected measurement values or functions of selected measurement values. A post-scan computation algorithm derives at least three independently-adjustable interactive control parameters responsive to at least displacements or angles the contact of a single area of threshold contact or threshold proximity. The system provides output control signals responsive to the independently-adjustable interactive control parameters. In one aspect of the invention, n algorithmic element for handling of regions of threshold contact or threshold proximity having non-convex shapes. In another aspect of the invention, an algorithmic element calculates the rate of change of one or more of the independently-adjustable interactive control parameters. Other aspects of the invention include shape and gesture recognition.

(51) **Int. Cl.**  
**G06F 3/01** (2006.01)  
**G06F 3/0488** (2013.01)  
(Continued)

(52) **U.S. Cl.**  
CPC ..... **G06F 3/04883** (2013.01); **G06F 3/005** (2013.01); **G06F 3/017** (2013.01);  
(Continued)

(58) **Field of Classification Search**  
CPC . G06F 3/04883; G06F 3/04886; G06F 3/041; G06F 3/0412; G06F 3/0414; G06F 3/0416; G06F 3/044; G06F 3/048

**25 Claims, 6 Drawing Sheets**

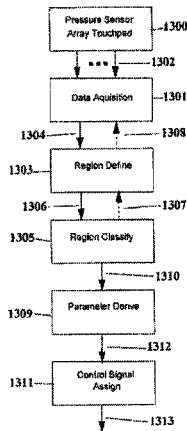

<b>Related U.S. Application Data</b>				
	division of application No. 09/313,533, filed on May 15, 1999, now Pat. No. 6,610,917.			
(60)	Provisional application No. 60/085,713, filed on May 15, 1998.			
(51)	<b>Int. Cl.</b>			
	<b>G10H 1/00</b> (2006.01)	5,159,140 A	10/1992	Kimpara et al.
	<b>G10H 1/34</b> (2006.01)	5,168,531 A	12/1992	Sigel
	<b>G10H 1/46</b> (2006.01)	5,194,862 A	3/1993	Edwards
	<b>G10H 3/18</b> (2006.01)	5,203,704 A	4/1993	McCloud
	<b>G10H 3/26</b> (2006.01)	5,214,615 A	5/1993	Bauer
	<b>G06F 3/00</b> (2006.01)	5,218,160 A	6/1993	Grob-Da Veiga
	<b>G06F 3/041</b> (2006.01)	5,233,123 A	8/1993	Rose et al.
(52)	<b>U.S. Cl.</b>	5,237,647 A	8/1993	Roberts et al.
	CPC .....	5,262,585 A	11/1993	Greene et al.
	<b>G06F 3/041</b> (2013.01); <b>G06F 3/0412</b> (2013.01); <b>G06F 3/0416</b> (2013.01); <b>G06F 3/0488</b> (2013.01); <b>G10H 1/00</b> (2013.01); <b>G10H 1/0058</b> (2013.01); <b>G10H 1/0066</b> (2013.01); <b>G10H 1/348</b> (2013.01); <b>G10H 1/46</b> (2013.01); <b>G10H 3/18</b> (2013.01); <b>G10H 3/26</b> (2013.01); <b>G10H 2220/521</b> (2013.01); <b>G10H 2220/525</b> (2013.01); <b>G10H 2230/095</b> (2013.01); <b>G10H 2230/101</b> (2013.01); <b>G10H 2230/115</b> (2013.01); <b>G10H 2230/145</b> (2013.01); <b>G10H 2230/271</b> (2013.01); <b>Y10S 84/10</b> (2013.01)	5,270,711 A	12/1993	Knapp
		5,281,754 A	1/1994	Farrett et al.
		5,292,999 A	3/1994	Tumura
		5,341,133 A	8/1994	Savoy et al.
		5,342,054 A	8/1994	Chang et al.
		5,347,295 A	9/1994	Aguinick et al.
		5,347,477 A	9/1994	Lee
		5,357,048 A	10/1994	Sgroi
		5,378,850 A	1/1995	Tumura
		5,386,219 A	1/1995	Greanias et al.
		5,389,730 A	2/1995	Wachi
		5,394,784 A	3/1995	Pierce et al.
		5,404,458 A	4/1995	Zetts
		5,408,914 A	4/1995	Breitweiser, Jr. et al.
		5,420,936 A	5/1995	Fitzpatrick et al.
		5,440,072 A	8/1995	Willis
		5,442,168 A	8/1995	Gurner et al.
		5,454,043 A	9/1995	Freeman
		5,459,282 A	10/1995	Willis
		5,471,008 A	11/1995	Fujita et al.
		5,475,214 A	12/1995	DeFranco et al.
		5,483,261 A	1/1996	Yasutake
		5,512,490 A	4/1996	Walt et al.
		5,531,227 A	7/1996	Schneider
		5,540,133 A	7/1996	Draper et al.
		5,543,591 A	8/1996	Gillespie et al.
		5,565,641 A	10/1996	Gruenbaum
		5,585,588 A	12/1996	Tumura
		5,592,572 A	1/1997	Le
		5,592,752 A	1/1997	Fu et al.
		5,594,469 A	1/1997	Freeman et al.
		5,596,697 A	1/1997	Foster et al.
		5,598,208 A	1/1997	McClintock
		5,604,323 A	2/1997	Hardie-bick
		5,617,855 A	4/1997	Waletzky et al.
		5,621,438 A	4/1997	Kamimura et al.
		5,625,704 A	4/1997	Prasad
		5,659,145 A	8/1997	Weil
		5,659,466 A	8/1997	Norris et al.
		5,659,625 A	8/1997	Marquardt
		5,662,111 A	9/1997	Cosman
		5,665,927 A	9/1997	Taki et al.
		5,668,338 A	9/1997	Hewlett et al.
		5,675,100 A	10/1997	Hewlett
		5,703,303 A	12/1997	Stewart
		5,717,939 A	2/1998	Bricklin et al.
		5,719,347 A	2/1998	Masubuchi et al.
		5,719,561 A	2/1998	Gonzales
		5,724,985 A	3/1998	Snell et al.
		5,741,993 A	4/1998	Kushimiya
		5,744,742 A	4/1998	Lindemann et al.
		5,748,184 A	5/1998	Shieh
		5,763,806 A	6/1998	Willis
		5,777,605 A	7/1998	Yoshinobu et al.
		5,786,540 A	7/1998	Westlund
		5,796,025 A	8/1998	Haake
		5,801,340 A	9/1998	Peter
		5,805,137 A	9/1998	Yasutake
		5,808,605 A	9/1998	Shieh
		5,824,930 A	10/1998	Ura et al.
		5,825,352 A	10/1998	Bisset et al.
		5,827,989 A	10/1998	Fay et al.
		5,841,428 A	11/1998	Jaeger et al.
		5,844,547 A	12/1998	Minakuchi et al.
		5,850,051 A	12/1998	Machover et al.
		5,852,251 A	12/1998	Su et al.
		5,870,083 A	2/1999	Shieh
		5,889,236 A	3/1999	Gillespie et al.
		5,907,115 A	5/1999	Matsunaga et al.
		5,932,827 A	8/1999	Osbourne et al.
(56)	<b>References Cited</b>			
	U.S. PATENT DOCUMENTS			
	3,591,699 A 7/1971 Cutler			
	3,612,741 A 10/1971 Marshall			
	3,651,242 A 3/1972 Evans			
	3,730,046 A 5/1973 Spence			
	3,742,113 A 6/1973 Cohen			
	3,742,133 A 6/1973 O'Sullivan			
	3,805,091 A 4/1974 Colin			
	3,813,473 A 5/1974 Terymenko			
	3,878,748 A 4/1975 Spence			
	3,910,152 A 10/1975 Kusakawa			
	3,956,959 A 5/1976 Ebihara et al.			
	3,962,945 A 6/1976 Creager et al.			
	4,075,921 A 2/1978 Heet			
	4,080,867 A 3/1978 Ratanangsu			
	4,117,413 A 9/1978 Moog			
	4,122,742 A 10/1978 Deutsch			
	4,151,368 A 4/1979 Fricke et al.			
	4,182,213 A 1/1980 Iodice			
	4,274,321 A 6/1981 Swartz			
	4,318,327 A 3/1982 Toups			
	4,365,533 A 12/1982 Clark, Jr. et al.			
	4,563,933 A 1/1986 Kim			
	4,570,149 A 2/1986 Thornburg et al.			
	4,658,690 A 4/1987 Aitken et al.			
	4,686,332 A 8/1987 Greanias et al.			
	4,702,141 A 10/1987 Bonanno			
	4,748,676 A 5/1988 Miyagawa et al.			
	4,781,099 A 11/1988 Koike			
	4,794,838 A 1/1989 Corrigan, III			
	4,797,608 A 1/1989 White			
	4,852,444 A 8/1989 Hoover et al.			
	4,899,137 A 2/1990 Behrens et al.			
	4,915,005 A 4/1990 Shaffer et al.			
	4,974,599 A 12/1990 Suzuki			
	4,988,981 A 1/1991 Zimmerman et al.			
	4,991,488 A 2/1991 Fala et al.			
	5,033,352 A 7/1991 Kellogg et al.			
	5,045,687 A 9/1991 Gurner			
	5,070,399 A 12/1991 Martel			
	5,095,799 A 3/1992 Wallace et al.			
	5,146,833 A 9/1992 Lui			

(56)

References Cited

U.S. PATENT DOCUMENTS

5,943,052	A	8/1999	Allen et al.	8,345,014	B2	1/2013	Lim	
5,969,283	A	10/1999	Looney et al.	2001/0012000	A1	8/2001	Eberhard	
5,977,466	A	11/1999	Muramatsu	2001/0036299	A1	11/2001	Senior	
5,981,859	A	11/1999	Suzuki	2002/0005108	A1	1/2002	Ludwig	
5,981,860	A	11/1999	Isozaki et al.	2002/0005111	A1	1/2002	Ludwig	
5,982,302	A	11/1999	Ure	2002/0088337	A1	7/2002	Devecka	
5,986,201	A	11/1999	Starr et al.	2002/0093491	A1	7/2002	Gillespie et al.	
5,986,224	A	11/1999	Kent	2003/0003976	A1	1/2003	Mura	
6,002,808	A	12/1999	Freeman	2003/0151592	A1	8/2003	Ritter	
6,005,545	A	12/1999	Nishida et al.	2003/0188627	A1	10/2003	Longo	
6,018,118	A	1/2000	Smith et al.	2004/0074379	A1	4/2004	Ludwig	
6,037,937	A	3/2000	Beaton et al.	2004/0118268	A1	6/2004	Ludwig	
6,047,073	A	4/2000	Norris et al.	2004/0245438	A1	12/2004	Payne	
6,049,327	A	4/2000	Walker et al.	2004/0251402	A1	12/2004	Reime	
6,051,769	A	4/2000	Brown	2005/0078085	A1	4/2005	Casebolt et al.	
6,066,794	A	5/2000	Longo	2005/0120870	A1	6/2005	Ludwig	
6,069,326	A	5/2000	Henson et al.	2005/0179651	A1	8/2005	Ludwig	
6,071,193	A	6/2000	Suzuoki	2006/0086896	A1	4/2006	Han	
6,087,570	A	7/2000	Sherlock	2006/0250353	A1	11/2006	Yasutake	
6,091,012	A	7/2000	Takahashi	2006/0252530	A1	11/2006	Oberberger et al.	
6,100,461	A	8/2000	Hewitt	2006/0267957	A1	11/2006	Kolmykov-Zotov et al.	
6,104,317	A	8/2000	Panagrossi	2006/0278068	A1	12/2006	Nielsen et al.	
6,107,997	A	8/2000	Ure	2007/0044019	A1	2/2007	Moon	
6,128,003	A	10/2000	Smith et al.	2007/0063990	A1	3/2007	Park et al.	
6,137,479	A	10/2000	Olsen et al.	2007/0216641	A1	9/2007	Young et al.	
6,140,565	A	10/2000	Yamauchi et al.	2007/0229477	A1	10/2007	Ludwig	
6,188,776	B1	2/2001	Covell et al.	2007/0236477	A1	10/2007	Ryu et al.	
6,195,104	B1	2/2001	Lyons	2007/0291009	A1	12/2007	Wright et al.	
6,204,441	B1	3/2001	Asahi et al.	2008/0001925	A1	1/2008	XiaoPing	
6,225,975	B1	5/2001	Furuki et al.	2008/0010616	A1	1/2008	Algreatly	
6,256,046	B1	7/2001	Waters et al.	2008/0012832	A1	1/2008	GuangHai	
6,278,443	B1	8/2001	Amro et al.	2008/0034286	A1	2/2008	Selby	
6,285,358	B1	9/2001	Roberts	2008/0036743	A1*	2/2008	Westerman et al.	345/173
6,288,317	B1	9/2001	Willis	2008/0055263	A1	3/2008	Lemay et al.	
6,292,690	B1	9/2001	Petrucelli et al.	2008/0091453	A1	4/2008	Meehan et al.	
6,310,219	B1	10/2001	Sawaki et al.	2008/0122796	A1	5/2008	Jobs et al.	
6,310,279	B1	10/2001	Suzuki et al.	2008/0143690	A1	6/2008	Jang et al.	
6,310,610	B1	10/2001	Beaton et al.	2008/0158146	A1*	7/2008	Westerman	345/156
6,320,112	B1	11/2001	Lotze	2008/0158172	A1	7/2008	Hotelling et al.	
6,323,846	B1	11/2001	Westerman et al.	2008/0158185	A1*	7/2008	Westerman	345/173
6,335,861	B1	1/2002	Ramsey, III et al.	2008/0164076	A1	7/2008	Orsley	
6,360,019	B1	3/2002	Chaddha	2008/0168403	A1	7/2008	Westerman et al.	
6,362,411	B1	3/2002	Suzuki et al.	2008/0259053	A1	10/2008	Newton	
6,363,159	B1	3/2002	Rhoads	2008/0297482	A1	12/2008	Weiss	
6,373,475	B1	4/2002	Challis	2008/0300055	A1	12/2008	Lutnick et al.	
6,392,636	B1	5/2002	Ferrari et al.	2008/0309634	A1	12/2008	Hotelling et al.	
6,392,705	B1	5/2002	Chaddha	2009/0002333	A1	1/2009	Maxwell et al.	
6,400,836	B2	6/2002	Senior	2009/0006292	A1	1/2009	Block	
6,404,898	B1	6/2002	Rhoads	2009/0019996	A1	1/2009	Fujishima et al.	
6,408,087	B1	6/2002	Kramer	2009/0027351	A1	1/2009	Zhang et al.	
6,433,801	B1	8/2002	Moon et al.	2009/0051659	A1	2/2009	Mickelborough	
6,509,847	B1	1/2003	Anderson	2009/0124348	A1	5/2009	Yoseloff et al.	
6,570,078	B2	5/2003	Ludwig	2009/0146968	A1	6/2009	Narita et al.	
6,610,917	B2	8/2003	Ludwig	2009/0167701	A1	7/2009	Ronkainen	
6,703,552	B2	3/2004	Haken	2009/0254869	A1*	10/2009	Ludwig et al.	715/863
6,753,466	B1	6/2004	Lee	2010/0013860	A1	1/2010	Mandella et al.	
6,793,619	B1	9/2004	Blumental	2010/0044121	A1	2/2010	Simon et al.	
6,798,427	B1	9/2004	Suzuki et al.	2010/0060607	A1	3/2010	Ludwig	
6,835,887	B2	12/2004	Devecka	2010/0073318	A1	3/2010	Hu et al.	
6,888,057	B2	5/2005	Juskiewicz et al.	2010/0079385	A1	4/2010	Holmgren et al.	
6,920,619	B1	7/2005	Milekic	2010/0079405	A1	4/2010	Bernstein	
7,030,860	B1	4/2006	Hsu et al.	2010/0087241	A1	4/2010	Nguyen et al.	
7,176,373	B1	2/2007	Longo	2010/0090963	A1	4/2010	Dubs et al.	
7,309,829	B1	12/2007	Ludwig	2010/0110025	A1	5/2010	Lim	
7,408,108	B2	8/2008	Ludwig	2010/0117978	A1	5/2010	Shirado	
7,557,797	B2	7/2009	Ludwig	2010/0177118	A1	7/2010	Sytnikov et al.	
7,598,949	B2	10/2009	Han	2010/0231612	A1	9/2010	Chaudhri et al.	
7,611,409	B2	11/2009	Muir et al.	2010/0232710	A1	9/2010	Ludwig	
7,812,828	B2	10/2010	Westerman et al.	2010/0289754	A1	11/2010	Sleeman et al.	
7,936,341	B2	5/2011	Weiss	2010/0302172	A1	12/2010	Wilairat	
8,049,730	B2	11/2011	Joquet et al.	2010/0315337	A1	12/2010	Ferren et al.	
8,154,529	B2	4/2012	Sleeman et al.	2010/0328032	A1	12/2010	Rofougaran	
8,169,414	B2	5/2012	Lim	2011/0007000	A1	1/2011	Lim	
8,170,346	B2	5/2012	Ludwig	2011/0037735	A1	2/2011	Land et al.	
8,179,376	B2	5/2012	Griffin	2011/0057953	A1	3/2011	Horodezky	
				2011/0063251	A1	3/2011	Geaghan et al.	
				2011/0066984	A1	3/2011	Li	
				2011/0084928	A1	4/2011	Chang et al.	
				2011/0086706	A1	4/2011	Zalewski	

(56)

## References Cited

## U.S. PATENT DOCUMENTS

2011/0170745	A1	7/2011	Chen et al.
2011/0202889	A1	8/2011	Ludwig
2011/0202934	A1	8/2011	Ludwig
2011/0260998	A1	10/2011	Ludwig
2011/0261049	A1	10/2011	Cardno et al.
2011/0285648	A1	11/2011	Simon
2012/0007821	A1	1/2012	Zaliva
2012/0034978	A1	2/2012	Lim
2012/0050185	A1	3/2012	Davydov et al.
2012/0056846	A1	3/2012	Zaliva
2012/0106782	A1	5/2012	Nathan et al.
2012/0108323	A1	5/2012	Kelly et al.
2012/0133484	A1	5/2012	Griffin
2012/0192119	A1	7/2012	Zaliva
2012/0194461	A1	8/2012	Lim
2012/0194462	A1	8/2012	Lim
2012/0195522	A1	8/2012	Ludwig
2012/0223903	A1	9/2012	Ludwig
2012/0235940	A1	9/2012	Ludwig
2012/0262401	A1	10/2012	Rofougaran
2012/0280927	A1	11/2012	Ludwig
2012/0317521	A1	12/2012	Ludwig
2013/0004016	A1	1/2013	Karakotsios et al.
2013/0009896	A1	1/2013	Zaliva
2013/0038554	A1	2/2013	West

## FOREIGN PATENT DOCUMENTS

EP	0574213	3/1999
EP	0880091	1/2004
JP	8-76926	3/1996
JP	09-231004	9/1997
JP	11-119911	4/1999

## OTHER PUBLICATIONS

Pilu, M., et al., Training PDMs on models: The Case of Deformable Superellipses, Proceedings of the 7th British Machine Vision Conference, Edinburgh, Scotland, 1996, pp. 373-382, [online] [retrieved on Feb. 28, 2011] URL: <https://docs.google.com/viewer/a&pid=explorer&chrome=true&srcid=0BxWzm3JBpNpMNDI1MDIxZGUtNGZhZi00NzJhLWFhZD-MtNTJmYmRiMmWYyMjBh&authkey=CPeVx4wO&hl=en>.

Polynomial regression, [online] [retrieved on May 12, 2013] [http://en.wikipedia.org/wiki/Polynomial\\_regression](http://en.wikipedia.org/wiki/Polynomial_regression), Jul. 24, 2010, 4 pgs.

Prabhakar S., et al., "Learning fingerprint minutiae location and type," <http://www.cse.msu.edu/biometrics/Publications/Fingerprint/PrabhakarJainPankanti-MinaLocType-PR03.pdf>, Pattern Recognition 36 (8), 1847-1857.

Pressure Profile Systems, Jan. 29, 2011, [online] [retrieved on Jan. 29, 2011] URL: <http://www.pressureprofile.com>, 1 pg.

Principal component analysis, [online] [retrieved on Jun. 26, 2013] URL: <http://en.wikipedia.org/wiki/Principal-component-analysis>, Feb. 25, 2011, 9 pgs.

"Prewitt," <http://en.wikipedia.org/wiki/Prewitt>, Mar. 15, 2010, visited Feb. 28, 2011. Prewitt, [online] [retrieved on May 12, 2013] URL: <http://en.wikipedia.org/wiki/Prewitt>, Mar. 15, 2010, visited Feb. 28, 2011, 2 pgs.

Rekimoto, Jun, "Pick-and-Drop: A Direct Manipulation Technique for Multiple Computer Environments," Sony Computer Science Laboratory Inc., Tokyo, Japan, 1997, <http://www.sonycs.l.co.jp/person/rekimoto/papers/uist97.pdf>, last retrieved on May 30, 2013.

Review of KORG X-230 Drum (later called "Wave Drum"), Electronic Musician, Apr. 1994, 1 pg.

Reyes, E., An Automatic Goodness Index to Measure Fingerprint Minutiae Quality, Progress in Pattern Recognition, Image Analysis and Applications, Lecture Notes in Computer Science vol. 3773, 2005, pp. 578-585.

Rich, Robert "Buchla Lightning MIDI Controller", Electronic Musician, Oct. 1991.

Rich, Robert "Buchla Thunder", Electronic Musician, Aug. 1990.

Roberts Cross, [online] [retrieved on May 12, 2013] URL: <http://en.wikipedia.org/wiki/Roberts-Cross>, Jul. 20, 2010, visited Feb. 28, 2011, 3 pgs.

Ronse, Christian and Devijver, Pierre A., Connected Components in Binary Images: the Detection Problem, Research Studies Press/ John Wiley & Sons Inc. New York, 1984.

"Sensor Products LLC—Tactile Surface Pressure and Force Sensors," Oct. 26, 2006, <http://www.sensorprod.com>.

Shapiro, L. S., Affine Analysis of Image Sequences, Cambridge University Press, 1995, 25 pgs.

Snell, J. M., Sensors for Playing Computer Music with Expression, Proceedings of the Intl. Computer Music Conf. at Eastman, 1983, pp. 113-126.

Sobel Operator, [online] [retrieved on May 12, 2013] URL: <http://en.wikipedia.org/wiki/Sobel-operator>, Mar. 12, 2010, visited Feb. 28, 2011, 5 pgs.

Synaptics, Jan. 28, 2011, [online] [retrieved on May 12, 2013] URL: <http://www.synaptics.com>, 1 pg.

Tactile Pressure Measurement, Pressure Mapping Systems, and Force Sensors and Measurement Systems, [online] [retrieved on Aug. 6, 2013] URL: <http://www.tekscan.com>, 2 pgs.

Tactile Surface Pressure and Force Sensors, Sensor Products LLC, Oct. 26, 2006, [online] [retrieved on Aug. 6, 2013] URL: <http://www.sensorprod.com>, 2 pgs.

Turner, J., Myron Krueger Live, ctheory.net, [online] [retrieved on Nov. 19, 2013] <http://www.ctheory.net/articles.aspx?id=328>, Jan. 23, 2002, 8 pgs.

Venolia, D., et al., T-Cube: A Fast, Self-Disclosing Pen-Based Alphabet, CHI '94 Proceedings of the SIGCHI Conference on Human Factors in Computing Systems, Apr. 24-28, 1994, pp. 265-270.

VeriFinger Information, [online] [retrieved on Jun. 11, 2013] URL: <http://www.fingerprint-it.com/-sol-verifinger.html>, 2 pgs.

Verner J., Artif Starr Switch Company Ztar 624-D, Electronic Musician, Nov. 1994, 5 pgs.

Viberg, M., Subspace Fitting Concepts in Sensor Array Processing, Linkoping Studies in Science and Technology Dissertations No. 217, 1989, Dept. of Electrical Engineering, Linkoping University, Linkoping, Sweden, 15 pgs.

Videoplace, [online] [retrieved on Nov. 19, 2013] URL: <http://en.wikipedia.org/Videoplace>, last updated Sep. 3, 2013, 1 pg.

Walker, G., Touch and the Apple iPhone, Veritas et Visus, [online] [retrieved on May 12, 2013] URL: <http://www.veritasetvisus.com/VVTP-12,%20Walker.pdf>, Feb. 2007, pp. 50-54.

Want, R., et al., The PARCTAB ubiquitous computing experiment, 1995-1996, [online] [retrieved on Jun. 10, 2013] URL: <http://www.ece.rutgers.edu/~parashar/Classes/02-03/ece572/perv-reading/the-parctab-ubiquitous-computing.pdf>, 44 pgs.

Wilson, T.V., How the iPhone Works, howstuffworks, [online] [retrieved on May 12, 2013] URL: <http://electronics.howstuffworks.com/iphone2.htm>, Jan. 8, 2011, 11 pgs.

Wu, Y., et al., Vision-Based Gesture Recognition: A Review, Lecture Notes in Computer Science, Gesture Workshop, 1999, 12 pgs, [online] [retrieved May 21, 2014] URL: <http://www.google.com/url?sa=t&rct=j&q=&esrc=s&source=web&cd=1&ved=0CC0QFjAA&url=http%3A%2F%2Fwww.ece.northwestern.edu%2F~yingwu%2Fpapers%2Fconference%2F1999%2Fgw99.pdf&ei=DSJ9U7EFyryhBjKgsAN&usq=AFQCNFLko3GnUOZbQQ5dLr8WsXQSE3Fg&bvm=bv.67651124,d.cGU>.

Xsensor Technology Corporation, Feb. 7, 2011, [online] [retrieved on May 12, 2013] URL: <http://www.xsensor.com>, 1 pg.

Davis, R. C., et al., NotePals: Lightweight Note Taking by the Group, for the Group, University of California, Berkeley, Computer Science Division, 1998, 8 pgs.

Feb. 27, 2014 USPTO Non-Final Office Action in U.S. Appl. No. 13/038,365.

Buxton, Bill, Multi-Touch Systems That I Have Known and Loved, <http://www.billbuxton.com/multitouchOverview.html>, Jun. 12, 2014.

Hauptmann, Alexander G., Speech and Gestures for Graphic Image Manipulation, Dept. of Computer Science, Carnegie Mellon University, 1989.

(56)

**References Cited**

## OTHER PUBLICATIONS

Hauptmann, Alexander G.; McAvinney, Paul; Shepard, Sharon R., *Gesture Analysis for Graphic Manipulation*, Carnegie Mellon University Research Showcase @CMU, 1988.

Minsky, Margaret R., *Manipulating Simulated Objects with Real-world Gestures using a Force and Position Sensitive Screen*, Atari Cambridge Research, MIT, Jul. 1984.

Rubine, Dean and McAvinney, Paul, *Programmable Finger-tracking Instrument Controllers*, The MIT Press, *Computer Music Journal*, vol. 14, No. 1, Spring 1990.

Rubine, Dean Harris, *The Automatic Recognition of Gestures*, CMU-CS-91-202, Dec. 1991.

Rubine, Dean, *Combining Gestures and Direct Manipulation*, Information Technology Center, Carnegie Mellon University, May 3-7, 1992.

Rubine, Dean, *Specifying Gestures by Example*, Information Technology Center, Carnegie Mellon University, *Computer Graphics*, vol. 25, No. 4, Jul. 1991.

Westerman, Wayne, *Hand Tracking, Finger Identification, and Chordic Manipulation on a Multi-Touch Surface*, Spring 1999.

Jan. 4, 2013 USPTO Office Action (U.S. Appl. No. 13/549,285)—Our Matter 5308.

Oct. 8, 2013 USPTO Office Action (U.S. Appl. No. 11/761,978)—Our Matter 5306.

Oct. 16, 2014 USPTO Office Action (U.S. Appl. No. 14/292,770)—Our Matter 5317.

Nov. 10, 2011 USPTO Office Action (U.S. Appl. No. 11/761,978)—Our Matter 5306.

Dec. 10, 2010 USPTO Office Action (U.S. Appl. No. 11/761,978)—Our Matter 5306.

Dec. 20, 2013 USPTO Office Action (U.S. Appl. No. 13/794,138)—Our Matter 5311.

Feb. 5, 2013 USPTO Office Action (U.S. Appl. No. 13/470,725)—Our Matter 5309.

Feb. 26, 2014 USPTO Office Action (U.S. Appl. No. 14/141,257)—Our Matter 5312.

Feb. 26, 2014 USPTO Office Action (U.S. Appl. No. 14/141,297)—Our Matter 5313.

Feb. 9, 2015 USPTO Office Action (U.S. Appl. No. 11/004,449)—Our Matter 5321.

Mar. 14, 2014 USPTO Office Action (U.S. Appl. No. 14/160,505)—Our Matter 5307.

Mar. 11, 2014 USPTO Office Action (U.S. Appl. No. 14/141,328)—Our Matter 5314.

Mar. 13, 2014 USPTO Office Action (U.S. Appl. No. 14/160,511)—Our Matter 5315.

Mar. 22, 2010 USPTO Office Action (U.S. Appl. No. 11/761,978)—Our Matter 5306.

Apr. 10, 2014 USPTO Office Action (U.S. Appl. No. 13/794,138)—Our Matter 5311.

May 22, 2014 USPTO Office Action (U.S. Appl. No. 14/229,681)—Our Matter 5318.

Jun. 17, 2013 USPTO Office Action (U.S. Appl. No. 13/794,138)—Our Matter 5311.

Jun. 20, 2011 USPTO Office Action (U.S. Appl. No. 11/761,978)—Our Matter 5306.

Jul. 15, 2013 USPTO Office Action (U.S. Appl. No. 13/470,725)—Our Matter 5309.

Jul. 15, 2013 USPTO Office Action (U.S. Appl. No. 13/549,285)—Our Matter 5308.

Jul. 2, 2014 USPTO Office Action (U.S. Appl. No. 14/141,257)—Our Matter 5312.

Jul. 24, 2014 USPTO Office Action (U.S. Appl. No. 14/141,328)—Our Matter 5314.

Jul. 25, 2014 USPTO Office Action (U.S. Appl. No. 14/292,770)—Our Matter 5317.

Sep. 13, 2012 USPTO Office Action (U.S. Appl. No. 13/549,285)—Our Matter 5308.

Sep. 26, 2014 USPTO Office Action (U.S. Appl. No. 14/229,681)—Our Matter 5318.

Sep. 30, 2013 USPTO Office Action (U.S. Appl. No. 13/794,138)—Our Matter 5311.

USPTO Notice of Allowance dated Dec. 24, 2002 issued in U.S. Appl. No. 09/812,870, filed Mar. 19, 2001.

USPTO Non-Final Office Action Dated Feb. 27, 2014, in U.S. Appl. No. 13/038,365.

USPTO Notice of Allowance dated Jan. 10, 2008 issued in U.S. Appl. No. 10/683,914, filed Oct. 10, 2003.

USPTO Notice of Allowance dated Feb. 10, 2014 issued in U.S. Appl. No. 13/180,512, filed Jul. 11, 2011.

USPTO Notice of Allowance dated Mar. 12, 2012 issued in U.S. Appl. No. 12/511,930, filed Jul. 29, 2009.

USPTO Notice of Allowance dated Mar. 20, 2012 issued in U.S. Appl. No. 12/724,413, filed Mar. 15, 2010.

USPTO Notice of Allowance dated May 8, 2013 issued in U.S. Appl. No. 12/541,948, filed Aug. 15, 2009.

USPTO Notice of Allowance dated May 16, 2013 issued in U.S. Appl. No. 13/441,842, filed Apr. 7, 2012.

USPTO Notice of Allowance dated May 24, 2013 issued in U.S. Appl. No. 13/442,815, filed Apr. 9, 2012.

USPTO Notice of Allowance dated May 30, 2013 issued in U.S. Appl. No. 13/442,806, filed Apr. 9, 2012.

USPTO Notice of Allowance dated Sep. 13, 2013 issued in U.S. Appl. No. 13/846,830, filed Mar. 18, 2013.

USPTO Notice of Allowance dated Jun. 20, 2014 issued in U.S. Appl. No. 14/141,297, filed Dec. 26, 2013.

USPTO Notice of Allowance dated Dec. 26, 2013 issued in U.S. Appl. No. 13/549,285, filed Jul. 13, 2012.

USPTO Notice of Allowance dated Sep. 11, 2013 issued in U.S. Appl. No. 13/786,265, filed Mar. 5, 2013.

USPTO Notice of Allowance dated Sep. 18, 2013 issued in U.S. Appl. No. 13/786,346, filed Mar. 5, 2013.

USPTO Notice of Allowance dated Nov. 9, 2012 issued in U.S. Appl. No. 12/502,230, filed Jul. 13, 2009.

USPTO Notice of Allowance dated Dec. 6, 2013 issued in U.S. Appl. No. 13/731,946, filed Dec. 31, 2012.

USPTO Notice of Allowance dated Dec. 19, 2013 issued in U.S. Appl. No. 11/761,978, filed Jun. 12, 2007.

Artmuseum.net, *Pioneers*, Myron Krueger, *Responsive 1970*, [online] [retrieved on Nov. 19, 2013] URL: <http://web.archive.org/web/20070929094921/http://www.artmuseum.net/w2vr/timeline/Krueger.html>, Sep. 29, 2007, 1 pg.

Balda AG, Feb. 26, 2011, [online] [retrieved on May 12, 2013] URL: <http://www.balda.de>, 1 pg. "Balda AG," Feb. 26, 2011, <http://www.balda.de>.

Alonso-Fernandez, F., et al., *Fingerprint Recognition*, Chapter 4, *Guide to Biometric Reference Systems and Performance Evaluation*, (Springer, London, 2009, pp. 51-90, [online] [retrieved on Jun. 2, 2013] URL: <http://www2.hh.se/staff/josef/public/publications/alonso-fernandez09chapter.pdf>.

Bishop, C.M., *Pattern Recognition and Machine Learning*, Springer New York, 2006, pp. 561-593.

Bormans, J., *MPEG-4 Systems Need Specialized CPUs*, *EE Times*, Jan. 25, 1999, [retrieved Sep. 5, 2013] URL: <http://www.eetimes.com/document.asp?doc-id=1224500>, 2 pgs.

Buxton, W. A. S., *Two-Handed Document Navigation*, *Xerox Disclosure Journal*, 19(2), Mar./Apr. 1994 [online] URL: <http://www.billbuxton.com/2Hnavigation.html>, pp. 103-108.

Canny edge detector, [online] [retrieved on May 12, 2013] <http://en.wikipedia.org/wiki/Canny-edge-detector>, Mar. 5, 2010, 4 pgs.

Central Moment, Dec. 16, 2009, [online] [retrieved on Oct. 26, 2010] URL: <http://en.wikipedia.org/w/index.php?title=Central-moment&oldid=332048374>.

Cipolla, R., et al., *Computer Vision for Human-Machine Interaction*, Cambridge University Press, 1988, pp. 23-51, 97-122, 135-153, 191-265, 291-311.

Coefficient of variation, [online] [retrieved on May 12, 2013] URL: <http://en.wikipedia.org/wiki/Coefficient-of-variation>, Feb. 15, 2010, visited Feb. 28, 2011, 2 pgs.

Cypress Semiconductor, Feb. 28, 2011, [online] [retrieved on May 12, 2013] URL: <http://www.cypress.com>, 1 pg.

Dario P., et al., *Tactile sensors and the gripping challenge*, *IEEE Spectrum*, vol. 5, No. 22, Aug. 1985, pp. 46-52.

(56)

## References Cited

## OTHER PUBLICATIONS

- Davis, R. C., et al., NotePals: Lightweight Note Sharing by the Group, for the Group, [online] [retrieved on Jun. 2, 2013] URL: <http://dub.washington.edu:2007/projects/notepals/pubs/notepals-chi99-final.pdf>, 9 pgs.
- Digiouse, N., Biometric Touchscreen Recognizes Your Fingerprints, *Hearst Electronic Products*, Jul. 24, 2013, [online] [retrieved on Jul. 31, 2013] URL: <http://www.electronicproducts.com/Sensors-and-Transducers/Sensors-and-Transducers/Biometric-Touchscreen-Recognizes-Your-Fingerprints.aspx>.
- DIY Touchscreen Analysis, MOTO, [online] [retrieved on May 12, 2013] URL: <http://labs.moto.com/diy-touchscreen-analysis/>, Jul. 15, 2010, 23 pgs.
- Dulberg, M. S., et al. An Imprecise Mouse Gesture for the Fast Activation of Controls, IOS Press, Aug. 1999, [online] [retrieved on Jul. 9, 2013] URL: <http://www.csc.ncsu.edu/faculty/stamant/papers/interact.pdf.gz>, 10 pgs.
- Electronic Statistics Textbook, StatSoft, Inc., 2011, [online] [retrieved on Jul. 1, 2011] URL: <http://www.statsoft.com/textbook>, 1 pg.
- Pavlovic, V. I., et al., Visual Interpretation of Hand Gestures of Human-Computer Interacton: A Review, *IEEE Transactions on Pattern Analysis and Machine Intelligence*, Jul. 1987, 19(7), pp. 677-695.
- Euler Angles, 2011, [online] [retrieved on Jun. 30, 2011] URL: <http://en.wikipedia.org/w/index.php?title=Euler-angles&oldid=436460926>, 8 pgs.
- Fang, Y., et al., Dynamics of a Winner-Take-All Neural Network, *Neural Networks*, 9(7), Oct. 1996, pp. 1141-1154.
- Garcia Reyes, E., An Automatic Goodness Index to Measure Fingerprint Minutiae Quality, Progress in Pattern Recognition, Image Analysis and Applications, Lecture Notes in Computer Science vol. 3773, 2005, pp. 578-585, [online] [retrieved on Jun. 2, 2013] URL: <http://www.researchgate.net/publication/226946511-An-Automatic-Goodness-Index-to-Measure-Fingerprint-Minutiae-Quality/file/d912f50ba5e96320d5.pdf>.
- Otsu's method, [online] [retrieved on Jun. 26, 2013] URL: <http://en.wikipedia.org/wiki/Otsu-method>, Sep. 13, 2010, 2 pgs.
- Haken, L., An Indiscrete Music Keyboard, *Computer Music Journal*, Spring 1998, pp. 30-48.
- Han, J., Multi-Touch Sensing through LED Matrix Displays (video), [online] [retrieved on May 12, 2013] "<http://cs.nyu.edu/~jhan/ledtouch/index.html>," Feb. 18, 2011, 1 pg.
- Hara, Y., Matsushita demos multilayer MPEG-4 compression, *Electronic Engineering times*, Apr. 19, 1999, 1 pg.
- Hernandez-Leon, R., et al., Classifying using Specific Rules with High Confidence, 9th Mexican International Conference on Artificial Intelligence, IEEE, Nov. 2010, pp. 75-80.
- Holz, C., et al., Fiberio: A Touchscreen that Senses Fingerprints, Proceedings of the 26th Annual ACM Symposium on User Interface Software and Technology (UIST '13), Oct. 8-11, 2013, 5 pgs. [Jun. 11, 2014] [online] URL: <http://www.christianholz.net/fiberio.html>.
- Hough transform, [online] [retrieved on Feb. 13, 2010] URL: <http://en.wikipedia.org/wiki/Hough-transform>, Feb. 13, 2010, 7 pgs.
- Igel, C., et al., Improving the Rprop Learning Algorithm, Proceedings of the Second International ICSC Symposium on Neural Computation (NC 2000), 2000, [online] [retrieved on Jun. 2, 2013] URL: <http://citeseerx.ist.psu.edu/viewdoc/download?doi=10.1.1.17.3899&rep=rep1&type=pdf>, pp. 115-121.
- Johnson, C., Image sensor tracks moving objects in hardware, *Electronic Engineering Times*, Apr. 5, 1999, 1 pg.
- Johnson, Colin "Computer program recognizes facial expressions", *Electronic Engineering Times*, Apr. 12, 1999.
- Kaoss pad dynamic effect/controller, *Korg Proview Users' magazine Summer 1999*, 2 pgs.
- Kayaoglu, M., et al., Standard Fingerprint Databases: Manual Minutiae Labeling and Matcher Performance Analyses, arXiv preprint arXiv:1305.1443, 2013, 14 pgs, [online] [retrieved on Jun. 2, 2013] URL: <http://arxiv.org/ftp/arxiv/papers/1305/1305.1443.pdf>.
- Krueger, M. W., ACM Siggraph Touchware, *Pioneers*, [online] [retrieved on Nov. 19, 2013] URL: <http://www.siggraph.org/artdesign/gallery/S98/pione/pione3/krueger.html>, last updated 1999, 1 pg.
- Krueger, M., *Artmuseum.net, Pioneers, Responsive 1970*, [online] [retrieved on Nov. 19, 2013] URL: <http://web.archive.org/web/20070929094921/http://www.artmuseum.net/w2vr/timeline/Krueger.html>, Sep. 29, 2007, 1 pg.
- Leiberman, D., Touch screens extend grasp Into consumer realm, *Electronic Engineering Times*, Feb. 8, 1999.
- "Lim, Agrawal, and Nekludova" "A Fast Parallel Algorithm for Labelling Connected Components in Image Arrays" ", Technical Report Series, No. NA86-2, Thinking Machines Corp., 1986 (rev. 1987), Cambridge, Mass., USA."
- Lippold Haken, "An Indiscrete Music Keyboard," *Computer Music Journal*, Spring 1998, pp. 30-48.
- Local regression, Nov. 16, 2010, [online] [retrieved on Jun. 28, 2011] URL: <http://en.wikipedia.org/w/index.php?title=Local-regression&oldid=416762287>.
- Marks, P., Biometric Touchscreen Recognises Prints for First Time, *New Scientist*, Jul. 17, 2013, Issue 2926, 3 pgs. [online] [retrieved Jun. 11, 2013] URL: <http://www.newscientist.com/article/mg21929266.300?full=true&print=true#.U5n1uBA9WHN>.
- Moog, R. A., The Human Finger—A Versatile Electronic Music Instrument Component, *Audio Engineering Society Preprint*, 1977, New York, NY, 4 pgs.
- Pennywitt, Kirk "Robotic Tactile Sensing," *Byte*, Jan. 1986.
- Moyle, Michael, et al. "A Flick in the Right Direction: A Case Study of Gestural Input." *Conferences in Research and Practice in Information Technology*, vol. 18, Jan. 2005; New Zealand.
- Nguyen, N., et al., Comparisons of sequence labeling algorithms and extensions, Proceedings of the 24th International Conference on Machine Learning, 2007, [online] [retrieved on Jun. 2, 2013] URL: <http://www.cs.cornell.edu/~nhnguyen/icml07structured.pdf>, pp. 681-688.
- Nissen, S., Implementation of a Fast Artificial Neural Network Library (FANN), Department of Computer Science University of Copenhagen (DIKU), Oct. 31, 2003, [online] [retrieved on Jun. 21, 2013] URL: <http://mirror.transact.net.au/sourceforge/f/project/fa/fann/fann-doc/1.0/fann-doc-complete-1.0.pdf>, 92 pgs.
- Osian, M., et al., Fitting Superellipses to Incomplete Contours, *IEEE Computer Society Conference on Computer Vision and Pattern Recognition Workshops (CVPRW '04)*, Jun. 2004, 8 pgs.

\* cited by examiner

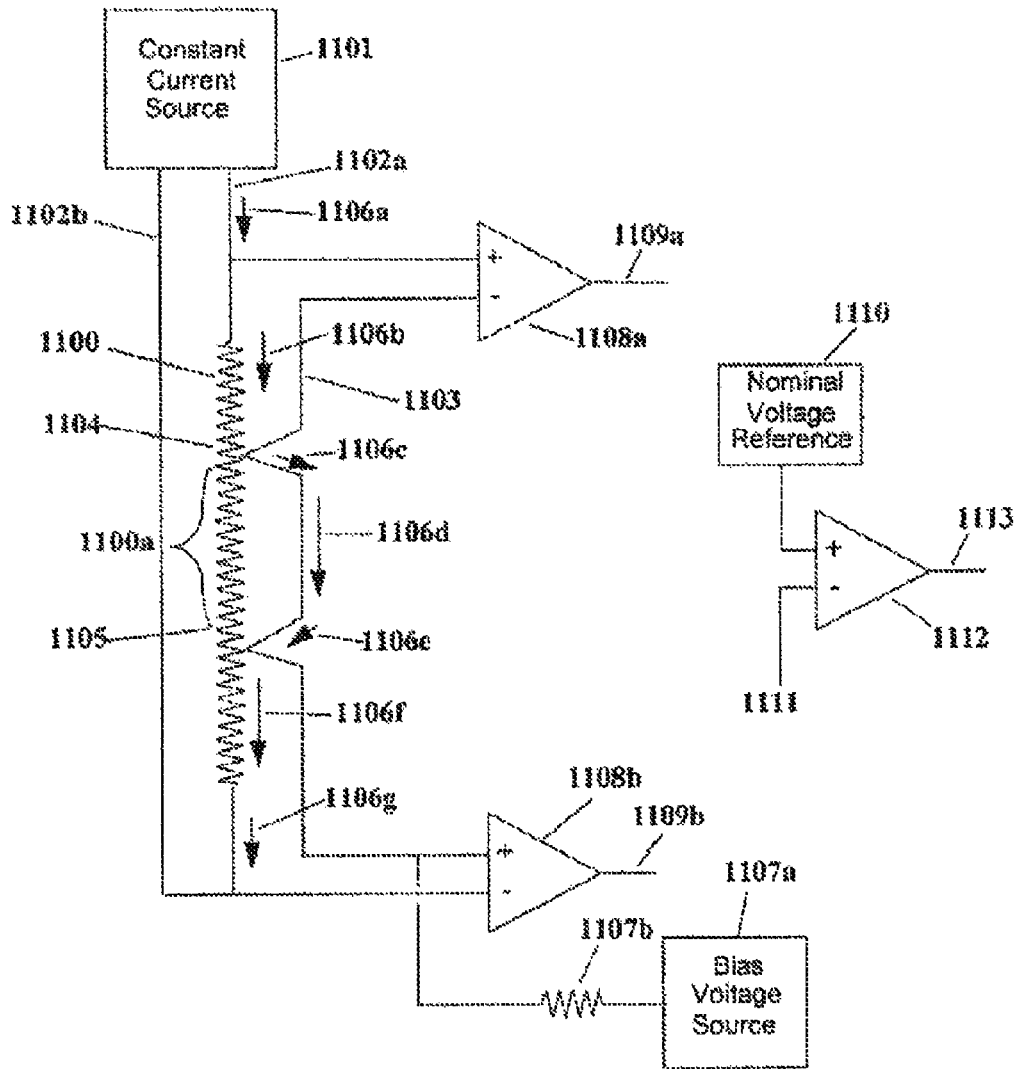

Figure 1

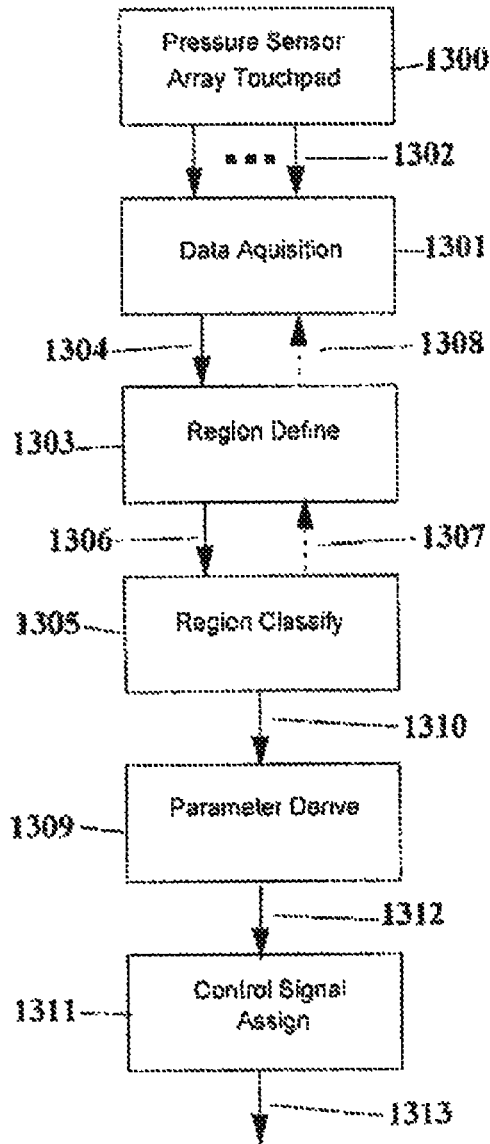

Figure 2



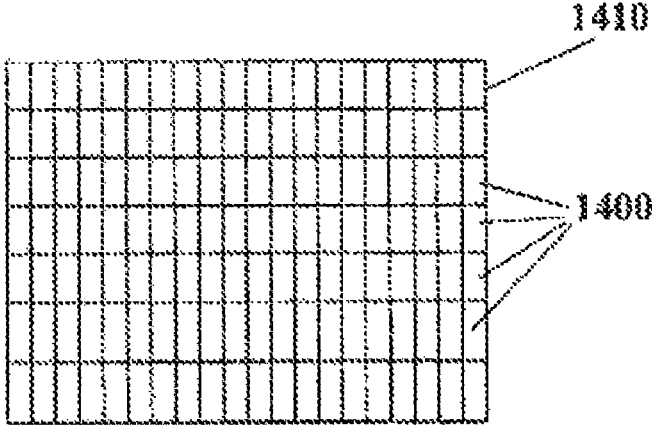

Figure 3

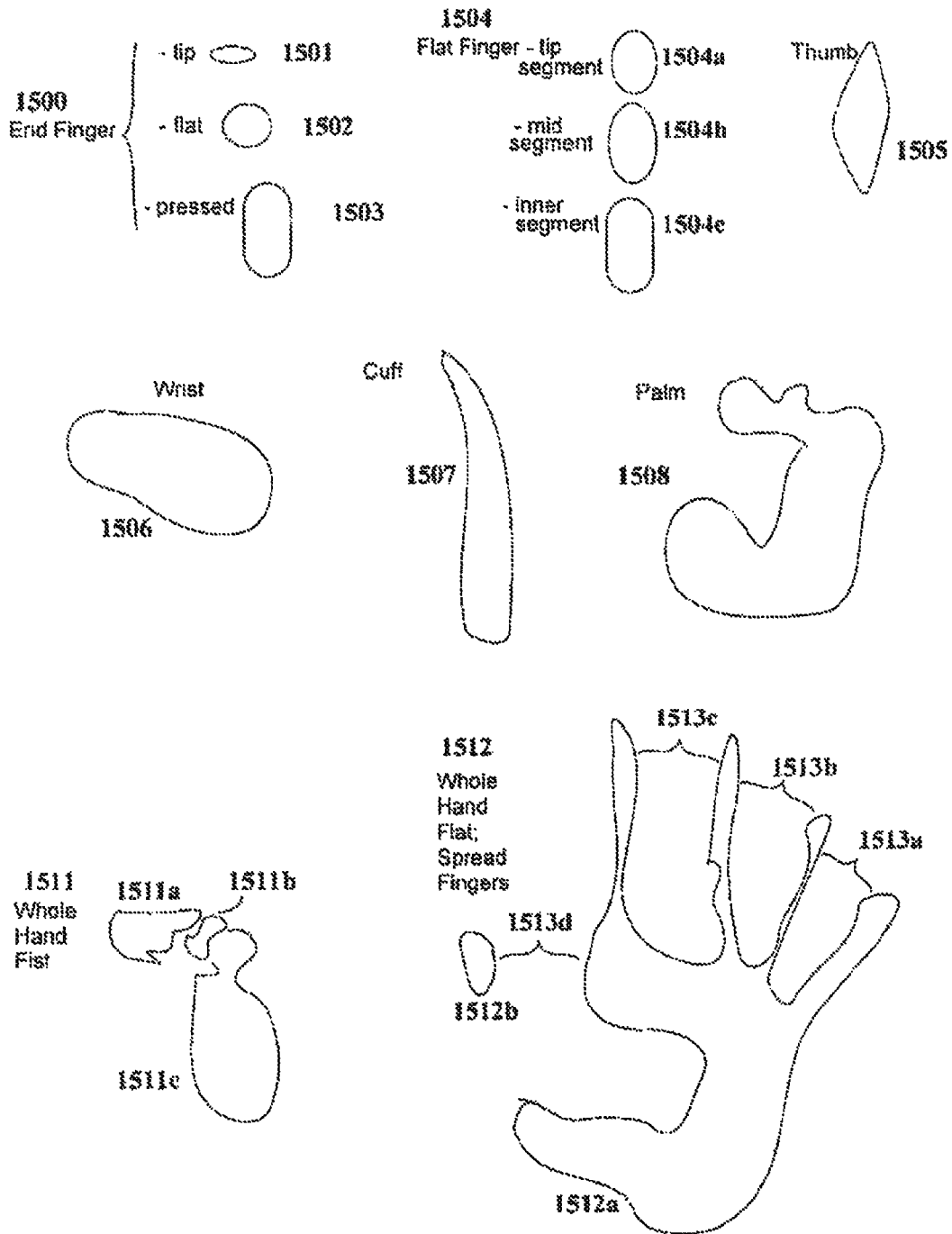

Figure 4

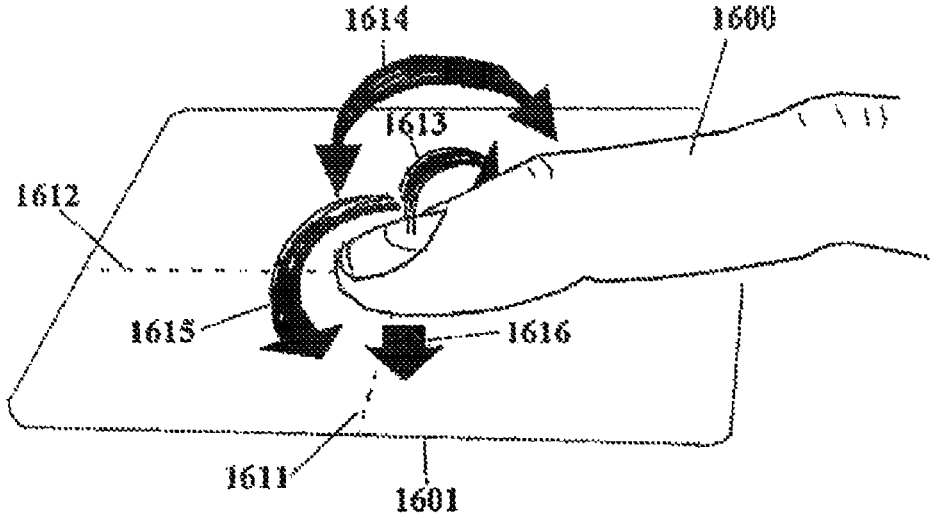

Figure 5

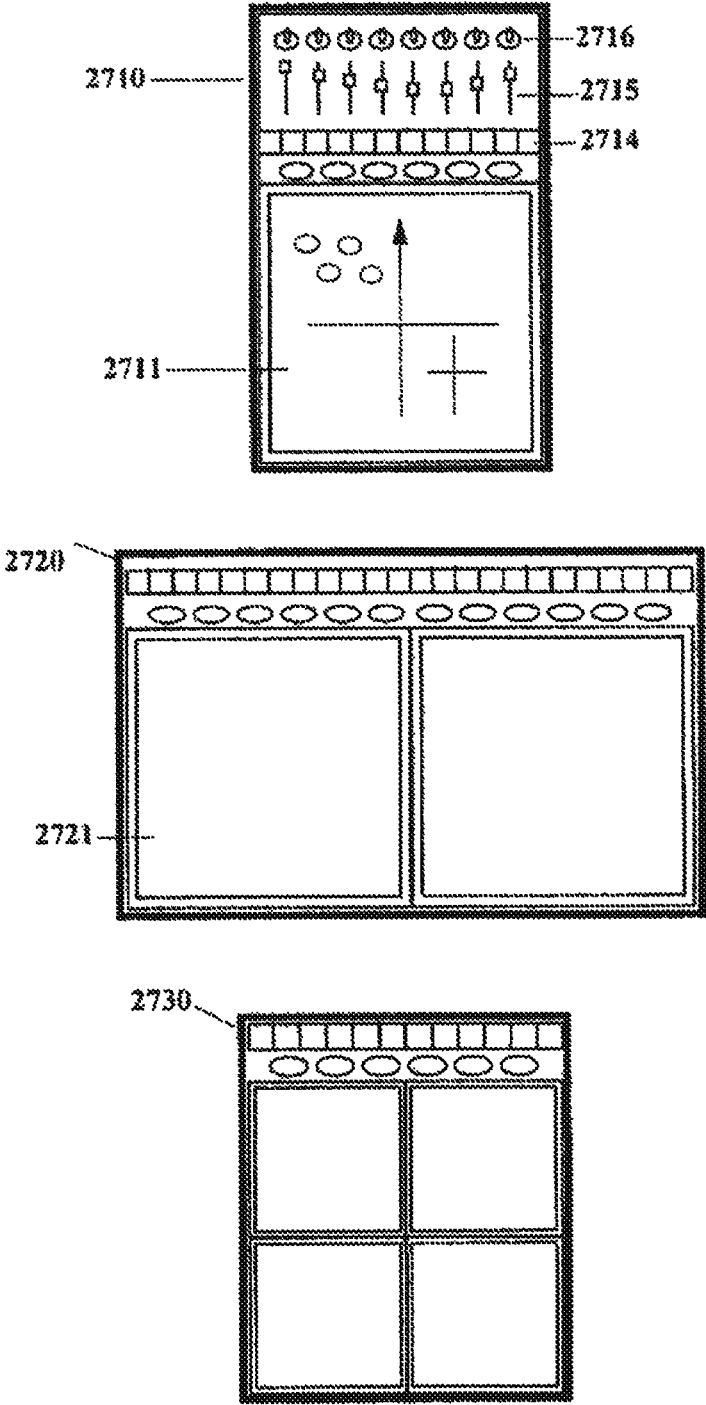

Figure 6

1

## TOUCH SCREEN APPARATUS FOR RECOGNIZING A TOUCH GESTURE

### CROSS REFERENCE TO RELATED APPLICATIONS

This application is a continuation of U.S. application Ser. No. 11/761,978, filed Jun. 12, 2007, which is a continuation of U.S. application Ser. No. 09/812,400, filed Mar. 19, 2001, now U.S. Pat. No. 7,786,370, issued Aug. 31, 2010, which is a division of U.S. application Ser. No. 09/313,533, filed May 15, 1999, now U.S. Pat. No. 6,610,917, issued Aug. 26, 2003, which claims benefit of priority of U.S. provisional application Ser. No. 60/085,713, filed May 15, 1998.

This application is also related to U.S. application Ser. No. 13/470,725, filed May 14, 2012.

### FIELD OF INVENTION

The present invention relates generally to a control system, and in particular, to a tactile input controller for controlling an associated system.

### SUMMARY OF THE INVENTION

Touchpad user interfaces for controlling external systems such as computers, machinery, and process environments via at least three independent control signals. The touchpad may be operated by hand, other parts of the body, or inanimate objects. Such an interface affords a wide range of uses in computer applications, machine and process control, and assistance to the disabled. In one embodiment simple contact position-sensing touchpads, producing control signals responsive to a contact region, are enhanced to provide several independent control signals. Enhancements may include velocity sensors, pressure sensors, and electronic configurations measuring contact region widths. Touch-screens positioned over visual displays may be adapted. According to other aspects pressure-sensor array touchpads are combined with image processing to responsively calculate parameters from contact regions. Six independent control parameters can be derived from each region of contact. These may be easily manipulated by a user. In one implementation, smaller pressure-sensor arrays are combined with data acquisition and processing into a chip that can be tiled in an array.

### DESCRIPTION OF THE DRAWINGS

The above and other aspects, features and advantages of the present invention will become more apparent upon consideration of the following description of preferred embodiments taken in conjunction with the accompanying drawing figures, wherein:

FIG. 1 shows an example of how two independent contact points can be independently discerned, or the dimensional-width of a single contact point can be discerned, for a resistance null/contact controller with a single conductive contact plate or wire and one or more resistive elements whose resistance per unit length is a fixed constant through each resistive element;

FIG. 2 shows how a pressure-sensor array touch-pad can be combined with image processing to assign parameterized interpretations to measured pressure gradients and output those parameters as control signals;

FIG. 3 illustrates the positioning and networking of pressure sensing and processing "mini-array" chips in larger contiguous structures;

2

FIG. 4 illustrates the pressure profiles for a number of example hand contacts with a pressure-sensor array;

FIG. 5 illustrates how six degrees of freedom can be recovered from the contact of a single finger; and

FIG. 6 illustrates examples of single, double, and quadruple touch-pad instruments with pads of various sizes and supplemental instrument elements.

### DETAILED DESCRIPTION

#### Overview

Described herein are two kinds of novel touch-pads. Null/contact touchpads are contact-position sensing devices that normally are in a null state unless touched and produce a control signal when touched whose signal value corresponds to typically one unique position on the touch-pad. A first enhancement is the addition of velocity and/or pressure sensing. A second enhancement is the ability to either discern each dimensional-width of a single contact area or, alternatively, independently discern two independent contact points in certain types of null/contact controllers. A third possible enhancement is that of employing a touch-screen instance of null/contact touch pad and positioning it over a video display.

The invention also provides for a pressure-sensor array touch-pad. A pressure-sensor array touch-pad of appropriate sensitivity range, appropriate "pixel" resolution, and appropriate physical size is capable of measuring pressure gradients of many parts of the human hand or foot simultaneously. A pressure-sensor array touch-pad can be combined with image processing to assign parameterized interpretations to measured pressure gradients and output those parameters as control signals. The pressure-sensor "pixels" of a pressure-sensor array are interfaced to a data acquisition stage; the data acquisition state looks for sensor pixel pressure measurement values that exceed a low-level noise-rejection/deformity-reject threshold; contiguous regions of sufficiently high pressure values are defined; the full collection of region boundaries are subjected to classification tests; various parameters are derived from each independent region; and these parameters are assigned to the role of specific control signals which are then output to a signal routing, processing, and synthesis entity.

It is possible to derive a very large number of independent control parameters which are easily manipulated by the operating user. For example, six degrees of freedom can be recovered from the contact of a single finger. A whole hand posture can yield 17 instantaneously and simultaneously measurable parameters which are independently adjustable per hand. The recognized existence and/or derived parameters from postures and gestures may be assigned to specific outgoing control signal formats and ranges. The hand is used throughout as an example, but it is understood that the foot or even other body regions, animal regions, objects, or physical phenomena can replace the role of the hand.

It will be evident to one of ordinary skill in the art that it is advantageous to have large numbers of instantaneously and simultaneously measurable parameters which are independently adjustable. For instance, a symbol in a 2-D CAD drawing can be richly interactively selected and installed or edited in moments as opposed to tens to hundreds of seconds as is required by mouse manipulation of parameters one or two at a time and the necessary mode-changes needed to change the mouse action interpretation. As a result, said touch-pad has applications in computer workstation control, general real-time machine control, computer data entry, and computer simulation environments.

Various hardware implementations are possible. A particularly advantageous implementation would be to implement a small pressure-sensor array together with data acquisition and a small processor into a single chip package that can be laid as tiles in a larger array.

#### Null/Contact Touch-Pads

Distinguished from panel controls and sensors are what will be termed null/contact touch-pads. This is a class of contact-position sensing devices that normally are in a null state unless touched and produce a control signal when touched whose signal value corresponds to typically one unique position on the touch-pad. Internal position sensing mechanisms may be resistive, capacitive, optical, standing wave, etc. Examples of these devices include one-dimensional-sensing ribbon controllers found on early music synthesizers, two-dimensional-sensing pads such as the early Kawala pad and more modern mini-pads found on some lap-top computers, and two-dimensional-sensing see-through touch-screens often employed in public computer kiosks.

The null condition, when the pad is untouched, requires and/or provides the opportunity for special handling. Some example ways to handle the untouched condition include:

- sample-hold (hold values issued last time sensor was touched, as does a joystick)
- bias (issue maximal-range value, minimal-range value, mid-range value, or other value)
- touch-detect on another channel (i.e., a separate out-of-band "gate" channel).

Additional enhancements can be added to the adaptation of null/contact touch-pad controllers as instrument elements. A first enhancement is, the addition of velocity and/or pressure sensing. This can be done via global impact and/or pressure-sensors. An extreme of this is implementation of the null/contact touch-pad controller as a pressure-sensor array; this special case and its many possibilities are described later.

A second enhancement is the ability to either discern each dimensional-width of a single contact area or alternatively, independently discern two independent contact points in certain types of null/contact controllers. FIG. 1 shows an example of how two independent contact points can be independently discerned, or the dimensional-width of a single contact point can be discerned, for a resistance null/contact controller with a single conductive contact plate (as with the Kawala pad product) or wire (as in some types of ribbon controller products) and one or more resistive elements whose resistance per unit length is a fixed constant through each resistive element. It is understood that a one-dimensional null/contact touch-pad typically has one such resistive element while a two-dimensional null/contact touch-pad typically has two such resistive elements that operate independently in each direction.

Referring to FIG. 1, a constant current source can be applied to the resistive element as a whole, developing a fixed voltage across the entire resistive element. When any portion of the resistive element is contacted by either a non-trivial contiguous width and/or multiple points of contact, part of the resistive element is shorted out, thus reducing the overall width-to-end resistance of the resistance element. Because of the constant current source, the voltage developed across the entire resistive element drops by an amount equal to the portion of the resistance that is shorted out.

The value of the voltage drop then equals a value in proportion to the distance separating the extremes of the wide and/or multiple contact points. By subtracting the actual voltage across the entire resistive element from the value this voltage is normally, a control voltage proportional to distance

separating the extremes of the wide and/or multiple contact points is generated. Simultaneously, the voltage difference between that of the contact plate/wire and that of the end of the resistive element closest to an external contact point is still proportional to the distance from said end to said external contact point. Using at most simple op-amp summing and/or differential amplifiers, a number of potential control voltages can be derived; for example one or more of these continuously-valued signals:

- value of distance difference between external contact points (or "width"; as described above via constant current source, nominal reference voltage, and differential amplifier)
- center of a non-trivial-width region (obtained by simple averaging, i.e., sum with gain of 1/2)
- value of distance difference between one end of the resistive element and the closest external contact point (simple differential amplifier)
- value of distance difference between the other end of the resistive element and the other external contact point (sum above voltage with "width" voltage with appropriate sign).

Further, through use of simple threshold comparators, specific thresholds of shorted resistive element can be deemed to be, for example, any of a single point contact, a recognized contact region width, two points of contact, etc., producing corresponding discrete-valued control signals. The detection of a width can be treated as a contact event for a second parameter analogous to the single contact detection event described at the beginning. Some example usages of these various continuous and discrete signals are:

- existence of widths or multiple contact points may be used to trigger events or timbre changes
- degree of widths may be used to control degrees of modulation or timbre changes
- independent measurement of each extremal contact point from the same end of the resistive element can be used to independently control two parameters. In the simplest form, one parameter is always larger than another; in more complex implementations, the trajectories of each contact point can be tracked (using a differentiator and controlled parameter assignment switch); as long as they never simultaneously touch, either parameter can vary and be larger or smaller than the other.

It is understood that analogous approaches may be applied to other null/contact touchpad technologies such as capacitive or optical.

A third possible enhancement is that of employing a touch-screen instance of null/contact touch-pad and positioning it over a video display. The video display could for example provide dynamically assigned labels, abstract spatial cues, spatial gradients, line-of-site cues for fixed or motor-controlled lighting, etc. which would be valuable for use in conjunction with the adapted null/contact touch-pad controller.

These various methods of adapted null/contact touch-pad elements can be used stand-alone or arranged in arrays. In addition, they can be used as a component or addendum to instruments featuring other types of instrument elements.

#### Pressure-Sensor Array Touch-Pads

The invention provides for use of a pressure-sensor array arranged as a touch-pad together with associated image processing. As with the null/contact controller, these pressure-sensor array touch-pads may be used stand-alone or organized into an array of such pads.

It is noted that the inventor's original vision of the below described pressure-sensor array touch-pad was for applications not only in music but also for computer data entry,

computer simulation environments, and real-time machine control, applications to which the below described pressure-sensor array touch-pad clearly can also apply.

A pressure-sensor array touch-pad of appropriate sensitivity range, appropriate “pixel” resolution, and appropriate physical size is capable of measuring pressure gradients of many parts of the flexibly-rich human hand or foot simultaneously. FIG. 2 shows how a pressure sensor array touch-pad can be combined with image processing to assign parameterized interpretations to measured pressure gradients and output those parameters as control signals.

The pressure-sensor “pixels” of a pressure-sensor array touch-pad **1300** are interfaced to a data acquisition stage **1301**. The interfacing method may be fully parallel but in practice may be advantageously scanned at a sufficiently high rate to give good dynamic response to rapidly changing human touch gestures. To avoid the need for a buffer amplifier for each pressure-sensor pixel, electrical design may carefully balance parasitic capacitance of the scanned array with the electrical characteristics of the sensors and the scan rates; electrical scanning frequencies can be reduced by partitioning the entire array into distinct parts that are scanned in parallel so as to increase the tolerance for address settling times and other limiting processes.

Alternatively, the pressure-sensor array **1300** may be fabricated in such a way that buffer amplifier arrays can be inexpensively attached to the sensor array **1300**, or the sensors may be such that each contains its own buffer amplifier; under these conditions, design restrictions on scanning can be relaxed and operate at higher speeds. Although the pressure sensors may be likely analog in nature, a further enhancement would be to use digital-output pressure-sensor elements or sub-arrays.

The data acquisition stage **1301** looks for sensor pixel pressure measurement values that exceed a low-level noise-rejection/deformity-rejection threshold. The sufficiently high pressure value of each such sensor pixel is noted along with the relative physical location of that pixel (known via the pixel address). This noted information may be stored “raw” for later processing and/or may be subjected to simple boundary tests and then folded into appropriate running calculations as will be described below. In general, the pressure values and addresses of sufficiently high pressure value pixels are presented to a sequence of processing functions which may be performed on the noted information:

- contiguous regions of sufficiently high pressure values are defined (a number of simple run-time adjacency tests can be used; many are known—see for example [Ronse; Viberg; Shaperio; Hara])

- the full collection of region boundaries are subjected to classification tests; in cases a given contiguous region may be split into a plurality of tangent or co-bordered independently recognized regions

- various parameters are derived from each independent region, for example geometric center, center of pressure, average pressure, total size, angle-of-rotation-from-reference for non-round regions, second-order and higher-order geometric moments, second-order and higher-order pressure moments, etc.

- assignment of these parameters to the role of specific control signals (note events, control parameters, etc.) which are then output to a signal routing, processing, and synthesis entity; for example, this may be done in the form of MIDI messages.

Because of the number of processes involved in such a pipeline, it is advantageous to follow a data acquisition stage **1301** with one or more additional processing stages **1303**,

**1305**, **1309**, and **1311**. Of the four example processing functions just listed, the first three fall in the character of image processing. It is also possible to do a considerable amount of the image processing steps actually within the data acquisition step, namely any of simple adjacency tests and folding selected address and pressure measurement information into running sums or other running pre-calculations later used to derive aforementioned parameters. The latter method can be greatly advantageous as it can significantly collapse the amount of data to be stored.

Regardless of whether portions of the image processing are done within or beyond the data acquisition stage, there are various hardware implementations possible. One hardware approach would involve very simple front-end scanned data acquisition hardware and a single high-throughput microprocessor/signal-processor chip. Alternatively, an expanded data acquisition stage may be implemented in high-performance dedicated function hardware and this would be connected to a lower performance processor chip. A third, particularly advantageous implementation would be to implement a small pressure-sensor array together with data acquisition and a small processor into a single low-profile chip package that can be laid as tiles in a nearly seamless larger array. In such an implementation all image processing could in fact be done via straightforward partitions into message-passing distributed algorithms.

One or more individual chips could direct output parameter streams to an output processor which would organize and/or assign parameters to output control channels, perhaps in a programmable manner under selectable stored program control. A tiled macro array of such “sensor mini-array” chips could be networked by a tapped passive bus, one- or two-dimensional mode active bus daisy-chain, a potentially expandable star-wired centralized message passing chip or subsystem, or other means.

Creating a large surface from such “tile chips” will aid in the serviceability of the surface. Since these chips can be used as tiles to build a variety of shapes, it is therefore possible to leverage a significant manufacturing economy-of-scale so as to minimize cost and justify more extensive feature development. Advanced seating and connector technologies, as used in laptops and other high-performance miniature consumer electronics, can be used to minimize the separation between adjacent chip “tiles” and resultant irregularities in the tiled-surface smoothness. A tiled implementation may also include a thin rugged flexible protective film that separates the sensor chips from the outside world. FIG. 3 illustrates the positioning and networking of pressure sensing and processing “mini-array” chips **1400** in larger contiguous structures **1410**.

With the perfection of a translucent pressure-sensor array, it further becomes possible for translucent pressure-sensor arrays to be laid atop aligned visual displays such as LCDs, florescent, plasma, CRTs, etc. as was discussed above for null/contact touch-pads. The displays can be used to label areas of the sensor array, illustrate gradients, etc. Note that in the “tile chip” implementation, monochrome or color display areas may indeed be built into each chip.

Returning now to the concept of a pressure-sensor array touch-pad large enough for hand-operation: examples of hand contact that may be recognized, example methods for how these may be translated into control parameters, and examples of how these all may be used are now described. In the below the hand is used throughout as an example, but it is understood that the foot or even other body regions, animal regions, objects, or physical phenomena can replace the role of the hand in these illustrative examples.

FIG. 4 illustrates the pressure profiles for a number of example hand contacts with a pressure-sensor array. In the case 1500 of a finger's end, pressure on the touch-pad pressure-sensor array can be limited to the finger tip, resulting in a spatial pressure distribution profile 1501; this shape does not change much as a function of pressure. Alternatively, the finger can contact the pad with its flat region, resulting in light pressure profiles 1502 which are smaller in size than heavier pressure profiles 1503. In the case 1504 where the entire finger touches the pad, a three-segment pattern (1504a, 1504b, 1504c) will result under many conditions; under light pressure a two segment pattern (1504b or 1504c missing) could result. In all but the lightest pressures the thumb makes a somewhat discernible shape 1505 as do the wrist 1506, cuff 1507, and palm 1508; at light pressures these patterns thin and can also break into disconnected regions. Whole hand patterns such as the first 1511 and flat hand 1512 have more complex shapes. In the case of the first 1511, a degree of curl can be discerned from the relative geometry and separation of sub-regions (here depicted, as an example, as 1511a, 1511b, and 1511c). In the case of the whole flat hand 1512, there can be two or more sub-regions which may be in fact joined (as within 1512a) and/or disconnected (as an example, as 1512a and 1512b are); the whole hand also affords individual measurement of separation "angles" among the digits and thumb (1513a, 1513b, 1513c, 1513d) which can easily be varied by the user.

Relatively simple pattern recognition software can be used to discern these and other hand contact patterns which will be termed "postures." The pattern recognition working together with simple image processing may, further, derive a very large number of independent control parameters which are easily manipulated by the operating user. In many cases it may be advantageous to train a system to the particulars of a specific person's hand(s) and/or specific postures. In other situations the system may be designed to be fully adaptive and adjust to a person's hand automatically. In practice, for the widest range of control and accuracy, both training and ongoing adaptation may be useful. Further, the recognized postures described thus far may be combined in sequence with specific dynamic variations among them (such as a finger flick, double-tap, etc.) and as such may be also recognized and thus treated as an additional type of recognized pattern; such sequential dynamics among postures will be termed "gestures."

The admission of gestures further allows for the derivation of additional patterns such as the degree or rate of variation within one or more of the gesture dynamics. Finally, the recognized existence and/or derived parameters from postures and gestures may be assigned to specific outgoing control signal formats and ranges. Any training information and/or control signal assignment information may be stored and recalled for one or more players via stored program control.

For each recognized pattern, the amount of information that can be derived as parameters is in general very high. For the human hand or foot, there are, typically, artifacts such as shape variation due to elastic tissue deformation that permit recovery of up to all six degrees of freedom allowed in an object's orientation in 3-space.

FIG. 5 illustrates how six degrees of freedom can be recovered from the contact of a single finger. In the drawing, the finger 1600 makes contact with the touch-pad 1601 with its end segment at a point on the touch-pad surface determined by coordinates 1611 and 1612 (these would be, for example, left/right for 1611 and forward/backward for 1612). Fixing this point of contact, the finger 1600 is also capable of rotational twisting along its length 1613 as well as rocking back

and forth 1614. The entire finger can also be pivoted with motion 1615 about the contact point defined by coordinates 1611 and 1612. These are all clearly independently controlled actions, and yet it is still possible in any configuration of these thus far five degrees of freedom, to vary the overall pressure 1616 applied to the contact point. Simple practice, if it is even needed, allows the latter overall pressure 1616 to be independently fixed or varied by the human operator as other parameters are adjusted.

In general other and more complex hand contacts, such as use of two fingers, the whole hand, etc. forfeit some of these example degrees of freedom but often introduce others. For example, in the quite constrained case of a whole hand posture, the fingers and thumb can exert pressure independently (5 parameters), the finger and thumb separation angles can be varied (4 parameters), the finger ends 1504a can exert pressure independently from the middle 1504b and inner 1504c segments (4 parameters), the palm can independently vary its applied pressure (1 parameter) while independently tilting/rocking in two directions (2 parameters) and the thumb can curl (1 parameter), yielding 17 instantaneously and simultaneously measurable parameters which are independently adjustable per hand. Complex contact postures may also be viewed as, or decomposed into, component sub-postures (for example here, as flat-finger contact, palm contact, and thumb contact) which would then derive parameters from each posture independently. For such complex contact postures, recognition as a larger compound posture which may then be decomposed allows for the opportunity to decouple and/or renormalize the parameter extraction in recognition of the special affairs associated with and constraints imposed by specific complex contact postures.

It is noted that the derived parameters may be pre-processed for specific uses. One example of this would be the quantization of a parameter into two or more discrete steps; these could for example be sequentially interpreted as sequential notes of a scale or melody. Another example would be that of warping a parameter range as measured to one with a more musically expressive layout.

Next examples of the rich metaphorical aspects of interacting with the pressure-sensor array touch-pad are illustrated. In many cases there may be one or more natural geometric metaphor(s) applicable, such as associating left-right position, left-right twisting, or left-right rotation with stereo panning, or in associating overall pressure with volume or spectral complexity. In more abstract cases, there may be pairs of parameters that go together—here, for example with a finger end, it may be natural to associate one parameter pair with (left/right and forward/backward) contact position and another parameter pair with (left/right and forward/backward) twisting/rocking. In this latter example there is available potential added structure in the metaphor by viewing the twisting/rocking plane as being superimposed over the position plane. The superposition aspect of the metaphor can be viewed as an index, or as an input-plane/output-plane distinction for a two-input/two-output transformation, or as two separated processes which may be caused to converge or morph according to additional overall pressure, or in conjunction with a dihedral angle of intersection between two independent processes, etc.

Next, examples of the rich syntactical aspects of interacting with the pressure-sensor array touch-pad are illustrated. Some instruments have particular hand postures naturally associated with their playing. It is natural then to recognize these classical hand-contact postures and derive control parameters that match and/or transcend how a classical player would use these hand positions to evoke and control sound



from the instrument. Further, some postures could be recognized either in isolation or in gestural-context as being ones associated with (or assigned to) percussion effects while remaining postures may be associated with accompanying melodies or sound textures.

As an additional syntactic aspect, specific hand postures and/or gestures may be mapped to specific selected assignments of control signals in ways affiliated with specific purposes. For example, finger ends may be used for one collection of sound synthesis parameters, thumb for a second potentially partially overlapping collection of sound synthesis parameters, flat fingers for a third partially-overlapping collection, wrist for a fourth, and cuff for a fifth, and first for a sixth. In this case it may be natural to move the hand through certain connected sequences of motions; for example: little finger end, still in contact, dropping to flat-finger contact, then dropping to either palm directly or first to cuff and then to palm, then moving to wrist, all never breaking contact with the touch-pad. Such permissible sequences of postures that can be executed sequentially without breaking contact with the touch-pad will be termed “continuous grammars.”

Under these circumstances it is useful to set up parameter assignments, and potentially associated context-sensitive parameter renormalizations, that work in the context of selected (or all available) continuous grammars. For example, as the hand contact evolves as being recognized as one posture and then another, parameters may be smoothly handed-over in interpretation from one posture to another without abrupt changes, while abandoned parameters either hold their last value or return to a default value (instantly or via a controlled envelope).

Now a number of example applications of the pressure-sensor array touchpad are provided. It is known to be possible and valuable to use the aforementioned pressure-sensor array touch-pad, implicitly containing its associated data acquisition, processing, and assignment elements, for many, many applications such as general machine control and computer workstation control. One example of machine control is in robotics: here a finger might be used to control a hazardous material robot hand as follows:

left/right position: left/right hand position  
 in/out position: in/out hand position  
 in/out rock: up/down hand position  
 rotation: hand grip approach angle  
 overall pressure: grip strength  
 left/right twist: gesture to lock or release current grip from pressure control

A computer workstation example may involve a graphical Computer-Aided Design application currently requiring intensive mouse manipulation of parameters one or two at a time:

left/right position: left/right position of a selected symbol in a 2-D CAD drawing  
 in/out position: up/down position of a selected symbol in 2-D CAD drawing  
 left/right twist: symbol selection—left/right motion through 2-D palette  
 in/out rock: symbol selection—up/down motion through 2-D palette  
 rotation: rotation of selected symbol in the drawing  
 overall pressure: sizing by steps  
 tap of additional finger: lock selection into drawing or unlock for changes  
 tap of thumb: undo  
 palm: toggle between add new object and select existing object

Clearly a symbol can be richly interactively selected and installed or edited in moments as opposed to tens to hundreds of seconds as is required by mouse manipulation of parameters one or two at a time and the necessary mode-changes needed to change the mouse action interpretation.

Touch-Pad Array

Touch-pad instrument elements, such as null/contact types and pressure-sensor array types described earlier, can be used in isolation or arrays to create electronic controller instruments. The touch-pad(s) may be advantageously supplemented with panel controls such as push buttons, sliders, knobs as well as impact sensors for velocity-controlled triggering of percussion or pitched note events. If one or more of the touch-pads is transparent (as in the case of a null/contact touch screen overlay) one or more video, graphics, or alphanumeric displays may be placed under a given pad or group of pads.

FIG. 6 illustrates examples of single touchpad, double touchpad, and quadruple touchpad instruments with pads of various sizes. A single touch-pad could serve as the central element of such an instrument, potentially supplemented with panel controls such as push buttons, sliders, knobs as well as impact sensors. In FIG. 6, a transparent pad superimposed over a video, graphics, or one or more alphanumeric displays is assumed, and specifically shown is a case of underlay graphics cues being displayed for the player. Two large sensors can be put side by side to serve as a general purpose left-hand/right-hand multi-parameter controller.

All publications and patent applications mentioned in this specification are herein incorporated by reference to the same extent as if each individual publication or patent application was specifically and individually indicated to be incorporated by reference. The invention now being fully described, it will be apparent to one of ordinary skill in the art that many changes and modifications can be made thereto without departing from its spirit or scope.

#### REFERENCES CITED

The following references are cited in this patent application using the format of the first one or two authors last name(s) within square brackets “[ ]”, multiple references within a pair of square brackets separated by semicolons “;”

[Ronse] Ronse, Christian and Devijver, Pierre A., *Connected Components in Binary Images: the Detection Problem*, John Wiley & Sons Inc. New York, 1984;

[Viberg] Viberg, Mats, *Subspace Fitting Concepts in Sensor Array Processing*, Linkoping Studies in Science and Technology. Dissertations No. 27 Linkoping, Sweden 1989;

[Shapiro] Shapiro, Larry S., *Affine Analysis of Image Sequences*, Cambridge University Press, 1995;

[Hara] Hara, Yoshiko “Matsushita demos multilayer MPEG-4 compression”, *Electronic Engineering Times*, Apr. 19, 1999.

What is claimed is:

1. An apparatus comprising:

a touch screen having a contiguous region sensing contact from at least a portion of a human hand on a surface of the touch screen, the touch screen comprising a visual display and a sensor array having a plurality of sensors, each sensor having a unique spatial location and an associated unique address, the sensing comprising generation of sensor measurement values associated with each of the plurality of sensors;

11

wherein sensors at a plurality of sensor spatial locations are configured to provide associated sensor measurement values responsive to the sensed contiguous region of contact;

a value of at least one control parameter for the contiguous region of contact responsive to a measured change in at least one of the associated sensor measurement values, the value obtained by performing a calculation based on the associated sensor measurement values and interpreting the results as signifying a touch gesture, wherein the at least one control parameter is associated with the touch gesture; and

at least one of the control parameters is assigned to a specific control signal;

wherein the touch gesture comprises a finger flick touch gesture recognized from sequential dynamics among postures.

2. The apparatus of claim 1, wherein sensor measurement values responsive to the sensed contiguous region of contact exceed a threshold.

3. The apparatus of claim 1, wherein the touch screen further tracks a trajectory of movement of the portion of the human hand contacting the surface of the transparent touch screen.

4. The apparatus of claim 1, wherein the at least one control parameter is responsive to a geometric center of the contiguous region of contact.

5. The apparatus of claim 1, wherein the at least one control parameter is responsive to a total size of the contiguous region of contact.

6. The apparatus of claim 1, wherein the touch screen further senses at least a second contiguous region of contact from another portion of the human hand on the touch screen, and the apparatus further derives a value of at least another control parameter responsive to the second contiguous region of contact.

7. The apparatus of claim 1, wherein the at least one control parameter assigned to the specific control signal comprises a particular control parameter.

8. The apparatus of claim 7, wherein the particular control parameter is assigned to the specific control signal using stored control signal assignment information.

9. The apparatus of claim 8, wherein a plurality of different assignments is stored for the particular control parameter.

10. The apparatus of claim 9, wherein the particular control parameter is dynamically assigned to the specific control signal for a specific purpose in a programmable manner under selectable stored program control.

11. The apparatus of claim 7, wherein the particular control parameter is dynamically assigned to the specific control signal in a programmable manner.

12. An apparatus comprising:

a touch screen having a contiguous region sensing contact from at least a portion of a human hand on a surface of the touch screen, the touch screen comprising a display and a sensor array comprising a plurality of sensors, each of the plurality of sensors configured with a unique spatial location and an associated unique address, each of the plurality of sensors configured to generate sensor measurement values;

wherein sensors at a plurality of sensor spatial locations are configured to provide associated sensor measurement values responsive to the contiguous region of contact;

12

a value of at least one control parameter for the contiguous region of contact responsive to a measured change in at least one of the associated sensor measurement values, the value obtained by performing a calculation based on the associated sensor measurement values and interpreting the results as signifying a touch gesture, wherein the at least one control parameter is associated with the touch gesture; and

at least one of the control parameters is assigned to a specific control signal;

wherein the touch gesture is recognized from sequential dynamics among hand contact patterns from a first posture associated with a first portion of a user hand at a first location on the touch screen to a second posture associated with a second portion of the user hand at a second location on the touch screen, wherein the first portion of the user hand and the second portion of the user hand are different.

13. The apparatus of claim 12, wherein the associated sensor measurement values responsive to the contiguous region of contact exceed a threshold.

14. The apparatus of claim 12, wherein the apparatus is further configured to track a trajectory of movement of the portion of the human hand contacting the surface of the touch screen.

15. The apparatus of claim 12, wherein the at least one control parameter is responsive to a geometric center of the contiguous region of contact.

16. The apparatus of claim 12, wherein the at least one control parameter is responsive to a total size of the contiguous region of contact.

17. The apparatus of claim 12, wherein the touch screen is further configured to sense at least a second contiguous region of contact from another portion of a human hand on a surface of the touch screen, and the apparatus is configured to derive a value of at least another control parameter responsive to the second contiguous region of contact.

18. The apparatus of claim 12, wherein the touch gesture comprises a plurality of finger postures executed sequentially without breaking contact with the touch screen.

19. The apparatus of claim 12, wherein the touch gesture employs a continuous grammar.

20. The apparatus of claim 12, wherein the apparatus is configured to respond to a velocity of touch gestures.

21. The apparatus of claim 12, wherein the at least one control parameter assigned to the specific control signal comprises a particular control parameter.

22. The apparatus of claim 21, wherein the particular control parameter is assigned to the specific control signal using stored control signal assignment information.

23. The apparatus of claim 22, wherein a plurality of different assignments is stored for the particular control parameter.

24. The apparatus of claim 23, wherein the particular control parameter is dynamically assigned to the specific control signal for a specific purpose in a programmable manner under selectable stored program control.

25. The apparatus of claim 21, wherein the particular control parameter is dynamically assigned to the specific control signal in a programmable manner.